

T/PUMP[®] SERIES LOCALIZED TEMPERATURE THERAPY SYSTEM

REF TP700

REF TP700C



Symbols

















	Operating instructions/Consult instructions for use
	General warning
	Caution
	Do not puncture
	Warning non-ionizing radiation
	Catalogue number
	Serial number
	Manufacturer
	For US Patents see www.C2Dx.com/patents
	Dangerous voltage
	Type BF applied part
	Medical Equipment Recognized by Underwriters Laboratories LLC With Respect to Electric Shock, Fire, and Mechanical Hazards only in accordance with UL 60601-1: 2003 and CAN/CSA-C22.2 No. 601-1, ASTM F 2196-2002
	Warm water fill line
	Cold water fill line
	Water levels
	Water flow
	CAUTION Federal law (USA) restricts this device to sale by or on the order of a physician.

Table of Contents

Warning/Caution/Note Definition.....	2
Summary of safety precautions.....	3
Introduction	4
Product description.....	4
Indications for use.....	4
Expected service life.....	4
Contraindications.....	4
Specifications.....	5
Product illustration.....	6
Product keypad.....	7
Contact information.....	7
Serial number location.....	8
Cleaning.....	9
Cleaning the external surface.....	9
Cleaning the water circuit and hoses.....	9
Quick reference replacement parts	10
Accessories.....	12
Preventive maintenance.....	14
Functional checks.....	14
Functional check and safety inspection form.....	15
Functional check setup - Clik-Tite® connectors	16
Functional check setup - Colder connection.....	16
Internal pump inspection.....	17
Flow and operating temperature test.....	17
Backup limit thermostat test.....	18
Water leak check.....	19
Ground resistance check.....	19
Current leakage check.....	20
Troubleshooting.....	21
Wiring diagram.....	23
Service	24
Protecting against Electrostatic Discharge (ESD).....	24
Water temperature control.....	24
Fluid system.....	24
Theory of operation.....	25
Reservoir.....	26
Upper front and rear housing.....	26
PC Board.....	26
Heater kit assembly.....	27
Heater assembly.....	27
T/Pump® Temperature Therapy Pump assembly.....	29

Warning/Caution/Note Definition

The words **WARNING**, **CAUTION**, and **NOTE** carry special meanings and should be carefully reviewed.

WARNING

Alerts the reader about a situation which, if not avoided, could result in death or serious injury. It may also describe potential serious adverse reactions and safety hazards.

CAUTION

Alerts the reader of a potentially hazardous situation which, if not avoided, may result in minor or moderate injury to the user or patient or damage to the product or other property. This includes special care necessary for the safe and effective use of the device and the care necessary to avoid damage to a device that may occur as a result of use or misuse.

Note: Provides special information to make maintenance easier or important instructions clearer.

Summary of safety precautions

Carefully read and strictly follow the warnings and cautions listed on this page. Service only by qualified personnel.

WARNING

- Always unplug the product before cleaning or disinfecting to avoid the risk of shock.
 - Risk of electric shock. Disconnect power before servicing or cleaning the **T/Pump® Temperature Therapy Pump**.
 - Only qualified service personnel should perform this Functional Check. Test procedures completed improperly may result in equipment damage.
 - Do not perform functional checks with an empty reservoir as this may result in damage to the product.
 - Always perform a functional check after any field service to make sure the product operates as intended.
-

CAUTION

- Do not modify the product or any components of the product. Modifying the product can cause unpredictable operation resulting in injury to patient or operator. Modifying the product also voids its warranty.
 - Do not use quaternary disinfectant solutions on the external surface of this product.
 - Do not spray cleaning or disinfectant solutions onto the pump. Frequent or prolonged disinfectant solutions may result in damage to the product.
 - Always use ESD protective equipment before opening antistatic bags and servicing electronic parts.
 - Do not place unprotected circuit boards on the floor.
 - Do not use the product next to or stacked with other equipment. If next to or stacked is necessary, observe the product to verify normal operation in the configuration in which it used.
-

Introduction

This manual assists you with the maintenance of your C2Dx® product. Read this manual before maintaining this product. Set methods and procedures to educate and train your staff on the safe maintenance of this product.

CAUTION

Do not modify the product or any components of the product. Modifying the product can cause unpredictable operation resulting in injury to patient or operator. Modifying the product also voids its warranty.

Note: C2Dx® continually seeks advancements in product design and quality. This manual contains the most current product information available at the time of release. There may be minor discrepancies between your product and this manual. If you have any questions, contact C2Dx® Customer Service or Technical Support at 888-902-2239

Product description

The **T/Pump®** Localized Temperature Therapy system delivers temperature controlled water. The water flows through an impeller driven pump through a bi-lumen hose. The hose connects to thermal transfer devices that can be applied over, under, or around the patient. Water temperature increases with the use of the heater. Water temperature decreases with the use of ice. The system delivers and removes thermal energy to and from the local anatomical sites. This occurs at the contact point of the patient skin and thermal transfer device to raise or lower the temperature of local anatomical sites.

Indications for use

The **T/Pump®** localized temperature therapy system is for use in supplying warm or cold water at controlled temperatures via thermal transfer devices. This is for the application of temperature therapy in situations where a physician determines that temperature therapy is necessary. Intended for adult and pediatric human patient's skin as attended by health care professionals and lay persons. For use in healthcare settings and home use.

Localized temperature therapy is of particular benefit in treating the following applications:

- Orthopedic conditions such as acute injuries, chronic pain, and muscle spasm and strains.
- Skin trauma such as abscesses, boils, bruises, burns, and contusions.
- Other medical conditions such as chronic arthritis, neuritis, phlebitis, tendonitis and IV infiltration, and symptoms such as infections and localized pain.

For use with non-acute traumatized tissue, impaired mental status, insensate body surface, and oxygen therapy. If an oxygen tent is in use, do not use the pump inside the tent.

Note: Applications are as determined by a physician.

Expected service life

The **T/Pump® Temperature Therapy Pump** controller has a two year expected service life under normal use conditions and with appropriate periodic maintenance.

Contraindications

C2Dx® promotes the assessment of each patient and appropriate usage by the operator. Contraindications for this product are for patients with the conditions specified below.

Introduction

Contraindications (Continued)

Heating contraindications include:

- Application to a body surface with compromised blood flow (Ischemia, area under pressure, arterial insufficiency)
- Application to a patient with an increased tendency to bleed (aggravates potential for hemorrhage)
- Application to a body surface with possible malignancy (tissue metabolism is increased and therefore, the growth potential of the malignant tissues)
- Treatment of hematoma within the first 24 to 48 hours (potential for re-bleeding and hemorrhage). Recent sprain or fracture (acute inflammatory response).
- In combination with topical solutions whose toxicity may be affected by the application of heat
- In combination with other heat sources

Cooling contraindications include:

- Application to a body surface with compromised blood flow (Ischemia, area under pressure, arterial insufficiency)
- Application to body surface with known vascular impairment such as frostbite, arteriosclerosis or ischemia
- Application to body surface in patients with hypersensitivity to cold, such as people with Raynaud's phenomenon, cold urticaria, cryoglobulinemia, and paroxysmal cold hemoglobinuria
- Application to body surface in patients with impaired sensation
- In combination with topical solutions whose toxicity may be affected by the application of cold

Specifications

Models		TP700 / TP700C	
Temperature setpoints Fahrenheit		107° F, 100° F, 95° F, 50° F	
Temperature setpoints Celsius		42° C, 38° C, 35° C, 10° C	
Therapy duration		20 or 30 minutes or continuous cycle	
Classification		Class I equipment with Type BF applied part suitable for continuous operation. Not classified for protection against ingress of liquid. Not classified for use in the presence of flammable anesthetics.	
Size		11.5 in. x 8 in. x 8 in.	29.2 cm x 20.3 cm x 20.3 cm
Weight	Reservoir empty	6.5 lb	2.9 kg
	Reservoir filled with water to the heating level	9 lb	4.0 kg
Maximum reservoir capacity		93 oz	2.75 l
Flow rate, minimum with pad attached		9 gph	34 lph
Average temperature accuracy		±2° F at 107° F	±1° C to 42° C
Maximum contact surface temperature		107° F	42° C
High limit safety temperature		110° F to 120° F	43.3° C to 49° C
Power cord		International (harmonized) 3 wire cord set	
Dual hose		10 ft	305 cm
Current leakage, maximum		100 µA	
Ground resistance, maximum		0.5 mΩ	
Electrical requirements		Voltage	120 VAC ±10%
		Frequency:	60 Hz
		Current in amperes	3.1

Introduction

Specifications (Continued)

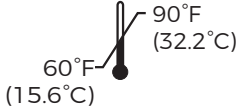
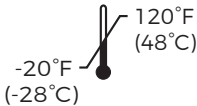
Environmental conditions	Operation	Storage and transportation
Ambient operating temperature	 60°F (15.6°C) to 90°F (32.2°C)	 -20°F (-28°C) to 120°F (48°C)

C2Dx® reserves the right to change specifications without notice.

Product illustration

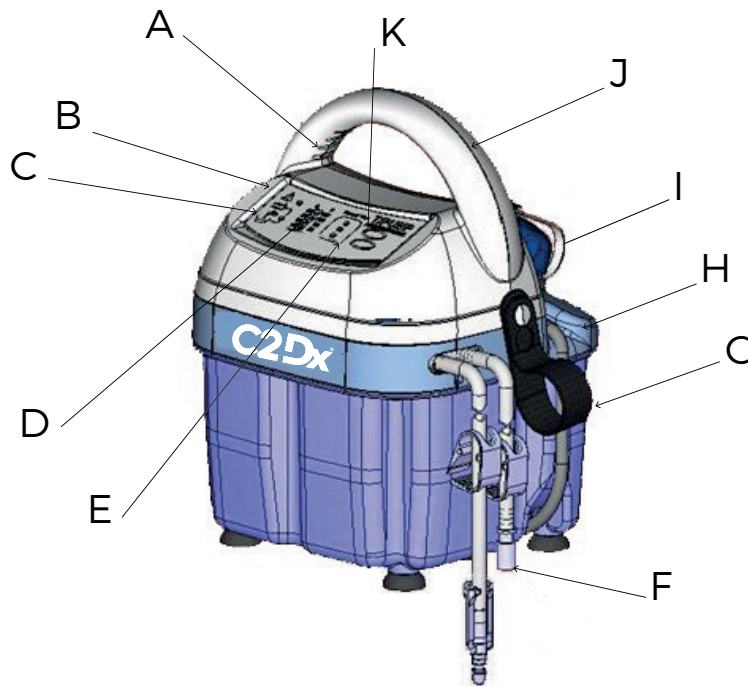

A	Handle vents
B	Keypad
C	Flow indicator
D	Warm or cool delivery
E	Therapy cycle times
F	Hose connections

G	Hose storage
H	Cord storage
I	Tethered open cap
J	Handle
K	On/Standby button

Introduction

Product keypad

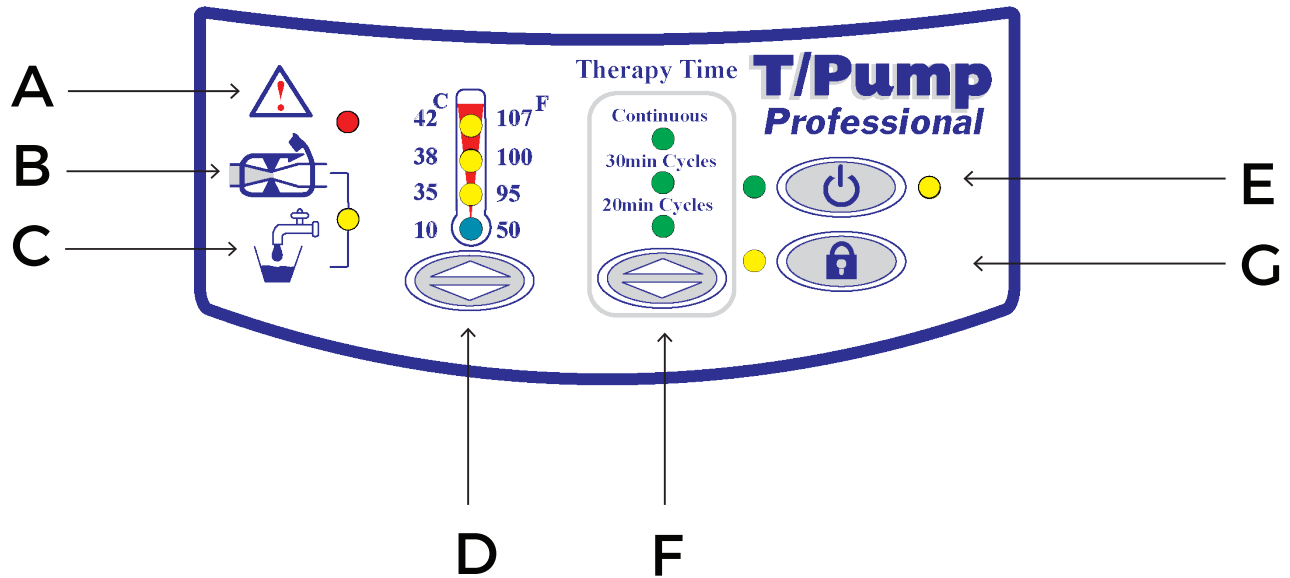

A	Indicator / Warning light	Red warning LED flashes with a short audible beep to inform the operator that the product has reached the desired temperature or is moving to the next cycle
B	Water flow	Check hoses or clamps for kinks or occlusions
C	Water level	Check water level
D	Setpoints	Toggle through the four setpoints, temperature in C and F
E	On/Standby button	Green indicates the unit is on / Yellow indicates power is supplied to the unit but the unit is not on
F	Therapy cycles	20 minute cycle, 30 minute cycle, or continuous cycle
G	Setpoint lock	Prevents tampering of settings

Contact information

Contact C2Dx® Customer Service or Technical Support at 888-902-2239.

C2Dx®, Inc
 555 E Eliza St, Ste A
 Schoolcraft, MI 49087
 USA

To view your operations or maintenance manual online, see www.c2dx.com/manuals

Have the serial number (A) of your C2Dx® product available when calling C2Dx® Customer Service or Technical Support. Include the serial number in all written communication.

Introduction

Serial number location



Cleaning

Empty and clean the pump on a monthly basis following these procedures. Complete this process more often depending on use.

WARNING

Always unplug the product before cleaning or disinfecting to avoid the risk of shock.

CAUTION

- Do not use quaternary disinfectant solutions on the external surface of this product.
 - Do not spray cleaning or disinfectant solutions onto the pump. Frequent or prolonged disinfectant solutions may result in damage to the product.
-

Cleaning the external surface

Cleaning the external surface

Recommended cleaning agents include:

- A clean damp cloth and mild soapy water
- Phenolic disinfectant or 10% bleach solution

To clean the external side of the pump:

1. Unplug the controller.
2. Wipe the outside of the product with the following:
 - a. Using a clean, soft cloth moistened with a mild soap and water solution to remove foreign material
 - b. Using a clean, soft cloth moistened with a phenolic disinfectant or 10% bleach solution.
3. Follow specified contact time in accordance with the manufacturer's instructions for use.
4. Using a clean, soft cloth, wipe the outside of the product with water.
5. Dry the external surface with a clean, dry cloth.

Cleaning the water circuit and hoses

Tools Required:

- Personal protective equipment, based on cleaning agent manufacturer's instructions
 - Soft, lint free cloth (2 or more)
1. Prepare a germicidal solution according to the manufacturer's instructions.
 2. Drain the pump.
 3. Connect the hose set together, where applicable, or attach a pad to the connector hose.
 4. Fill the reservoir to the heating water line on the back of the reservoir.
 5. Select 95° F (35° C) temperature on the keypad.
 6. Press the **On/Standby** button to start the pump.
 7. Circulate the solution for one hour.
 8. Drain the solution from the reservoir.
 9. Rinse and drain the reservoir with water.
 10. Dry the reservoir inside and outside with a dry, lint free cloth.

Quick reference replacement parts

These parts are currently available for purchase. Call C2Dx® Customer Service: 888-902-2239 for availability and pricing.

Item	Serial Number	Description	Quantity
1K	100822001	KIT: Upper front & Rear Housing. Includes both Front & Rear plastic housing, Label, Membrane Panel (TP700 / TP700C)	1
2K	100898000	KIT: PC Board/Sensor Assembly - This assembly comes with a precalibrated sensor and PCB assembly. They are a "Matched" set. Do not use the old sensor with the new PC Board or the old PC Board with the new sensor (TP700 / TP700C)	1
3K	100819001	KIT: Upper Rear Housing Assembly. Includes Rear Plastic Housing with Label (TP700 / TP700C)	1
4K	100818001	KIT: Upper Front Housing Assembly. Includes Front Plastic Housing with Membrane Panel (TP700 / TP700C)	1
5K	100821001	KIT: Heater Assembly. Includes Brass Manifold, 2 O-Rings, 4 Brass Fittings. (TP700 / TP700C)	1
6K	100820000	KIT: Reservoir Assembly. Includes Reservoir, Gasket, Rubber Feet, Label.	1
1	03394000	Fitting, Manifold	2
2	03791001	Strap Assembly - Hose	1
3	04152000	Fan	1
5	08086000	Hose Assembly - Clik-Tite® Connectors	1
6	08648000	Hose Assembly - quick disconnects (colder)	1
7	Source Locally	Tape, Teflon, 1/4" Wide	As required
8	Source Locally	Ty-Wrap, Self Locking	5
9	81002028	Tubing, PVC, Panacea 1/4 ID x 3/8 OD x 3 1/2" LG	1
10	81002048	Tubing, PVC, Panacea 1/4 ID x 3/8 OD x 6" LG	1
11	90018029	Screw, Machine 4-40 x 1/2" FH Phillips	9
12	90018075	Screw Mach PH CR 8-32 UNC 2A x 3/8 LG S	4
13	90018082	Screw, Machine Pan HD #8-32 x 1 SST	1
14	90049005	LockWasher, Spring #6 SST	4
15	90076018	Bushing, Straight Thru (HEYCO #1210)	2
16	90295019	O-Ring	1
17	90295020	O-Ring, Silicone	4
18	90385000	Cup, Suction	3
19	90514003	Screw Type "BT" Thread Cutting Pan HD SST. #4 x 5/16" LG	4
20	90514013	Screw Type "BT" Thread Cutting Pan HD SST. #6 x 7/8" LG	4
21	90514020	Screw Type "BT" Thread Cutting #8 x 3/4" LG	1
22	91275059	Label Ground Identification	1

Quick reference replacement parts

Item	Number	Description	Quantity
24	91390000	Toroid, Ferrite Ring	1
25	91454052	Screw, Mach, Fillister Head #6-32 x 1/4 LG SST	1
26	100092000	Connector Lever Nut 3 Terminal	2
28	100129000	Tray Assembly (TP700 / TP700C)	1
29	101157000	Impeller/Magnet Assembly	1
30	100132000	Impeller Housing Bottom	1
31	100133000	Impeller Housing Top	1
32	100134000	Pin, Impeller	1
33	100139000	Housing, Front Assembly	1
36	100152000	O-Ring, Reservoir	1
37	100261000	Motor/Plate Assembly (TP700 / TP700C)	1
38	100267000	Cord, Power Assy (TP700 / TP700C)	1
39/40	100269001	Membrane Panel - Professional (TP700 / TP700C)	1
41	100275000	Cap, Tethered, Rivet Assembly	1
42	101158000	Magnet Driver Assembly	1
43/44	100288001	Label, Instruction Professional (TP700)	1
46	100289001	Label, Ratings Professional (TP700)	1
48	100289003	Label, Ratings Professional with quick disconnects (TP700C)	1
49	100292000	Clip, Cord	1
50	100378000	Cap (for Impeller Pin)	1
51	100578000	Label, Danger	1
55	100256001	Heater Cartridge Assembly	1
56	0000-001-083	Label, product barcode TP700C	1
57	0000-001-084	Label, product barcode TP700	1

Accessories

These accessories may be available for use with your product. Confirm availability for your configuration or region. Call C2Dx® Customer Service: 888-902-2239.

Test tools

Catalog Number	Product Name	Number in Carton
TPT9	Flow and Temperature Tester	1
100925000	Test Probe Assembly	1

Cleaner

Catalog Number	Product Name	Number in Carton
8001-000-333	Ecolab 2.0	1

Optional accessories

Catalog Number	Product Name	Number in Carton
TPS2	Temperature therapy stand with storage basket and cord hooks	1
TPIV	IV pole mount plate	1

Notes

- Only use **Mul-T-Pad®** products with the **T/Pump® Temperature Therapy Pump**. The unique button design allows optimal water flow and provides trouble-free operation when the pad is folded.
- The **Mul-T-Pad®** series products with **Clik-Tite® connectors** can be interconnected to provide therapy to more than one body site at a time.

Mul-T-Pad® Model	Connector	Length	Width	Expected life in days / single patient use	Material	Quantity per carton
8002-062-012	For use with Clik-Tite® connectors	18 in. (46 cm)	13 in. (33 cm)	30	Nonwoven fabric on one side, pliable polymer on the other side	20
8002-062-022	For use with Clik-Tite® connectors	22 in. (56 cm)	15 in. (38 cm)	30	Nonwoven fabric on one side, pliable polymer on the other side	20
8002-062-026	For use with Clik-Tite® connectors	26 in. (66 cm)	18 in. (46 cm)	30	Nonwoven fabric on one side, pliable polymer on the other side	10
8002-062-222	For use with Clik-Tite® connectors	22 in. (56 cm)	15 in. (38 cm)	90 days / reusable	Heavy polymer, reusable	10

Accessories

8002-062-612	For use with Colder connectors	18 in. (46 cm)	13 in. (33 cm)	30	Non-woven fabric on both sides	10
8002-062-622	For use with Colder connectors	22 in. (56 cm)	15 in. (38 cm)	30	Non-woven fabric on both sides	10
8002-062-626	For use with Colder connectors	26 in. (66 cm)	18 in. (46 cm)	30	Non-woven fabric on both sides	10

Preventive maintenance

Remove product from service before you perform the preventive maintenance inspection. Check all items listed during annual preventive maintenance for all C2Dx® products. You may need to perform preventive maintenance checks more often based on your level of product usage. Service only by qualified personnel.

WARNING

Risk of electric shock. Disconnect power before servicing or cleaning the T/Pump® Temperature Therapy Pump.

Note: Change the water monthly or more often depending on use.

Inspect the following items:

- _____ Line cord, the plug, and the housing for cuts or cracked insulation and quality of the strain relief, if damaged replace
- _____ Membrane panel for cuts or cracks, if damaged replace
- _____ Plastic parts on the pump for cracks
- _____ Connectors for cracks and missing O-rings, replace connectors if necessary
- _____ Hose connections and connectors function properly
- _____ Pads and hoses are free from tears, cracks, and water leaks

Perform [Functional checks on page 14](#).

Inspection	Value	Okay	Action Needed	Action Taken
Measure current leakage <100 µA				

Product serial number:
Completed by:
Date:

Functional checks

Perform Functional Checks during maintenance, or after you repair an internal component, or as specified per your facilities preventive maintenance program. This is to make sure you have optimum performance, dependability, and safety of your product.

WARNING

- Only qualified service personnel should perform this Functional Check. Test procedures completed improperly may result in equipment damage.
- Do not perform functional checks with an empty reservoir as this may result in damage to the product.
- Always perform a functional check after any field service to make sure the product operates as intended.

This section provides a complete check of all T/Pump® Temperature Therapy Pump functions. See [\(Functional check and safety inspection form on page 15\)](#) to record test data. Follow the steps in this section. Pay attention to each step, and the expected result. If at any time you cannot get the expected result, press the **On/Standby** button to stop the test, then restart the procedure. If after a second attempt you cannot get the expected result, press **On/Standby** button to stop the test. Unplug the T/Pump® Temperature Therapy Pump and call your dealer or contact C2Dx® Technical Support Department for help.

Preventive maintenance

Functional checks (Continued)

Tools required for all functional test procedures:

- **TPT9** - to measure the temperature and the flow of the water entering the pad (Temperature test tool accuracy $\pm 0.2^{\circ}\text{F}$)
- To use Colder style quick disconnects, also order adapter hose P/N 77926000
- Stop watch
- **Mul-T-Pad**[®] Temperature Therapy Pad
- Test probe, P/N 100925000
- Current leakage meter
- Ground resistance meter
- Ohm meter
- #2 Phillips screwdriver
- Vacuum cleaner or air compressor
- [Functional check and safety inspection form on page 15](#)

Note: To order any of the parts listed, contact your dealer or contact C2Dx[®] customer service.

Functional check and safety inspection form

Inspection forms vary from hospital to hospital. The following sample form is intended as a guide to record the important parameters.

T/Pump [®] Temperature Therapy Pump functional check and safety inspection form					
Serial number:				Date:	
Model number:				Check one of the boxes	
Item		Value	Okay, no action	Action needed	Action taken
1	Inspect physical condition (line cord, plug, housing)				
	Inspect hose connections and connectors				
2	Measure flow, >7 gph (26.5 lph) indicate value				
3	Measure operating temperature at 107°F \pm 2°F (42°C \pm 1°C) indicate average				
4	Backup limit test 110°F - 120°F (43.3° C - 49°C)				
5	Water leak check				
6	Measure good resistance, <0.5 ohm indicate value				
7	Measure current leakage, <100 μ A (120 V)				

Preventive maintenance

Signature: _____

Functional checks (Continued)

Complete all the functional tests for the **T/Pump® Temperature Therapy Pump**. If the pump passes all the requirements of this functional check and safety inspection, the pump should be considered operational and suitable to return to service.

Functional check setup - **Clik-Tite®** connectors

Note: If the flow meter is connected in reverse, the flow meter will indicate no flow. Reverse the pump connections so that the male fitting (with black O-ring) is on the supply side.

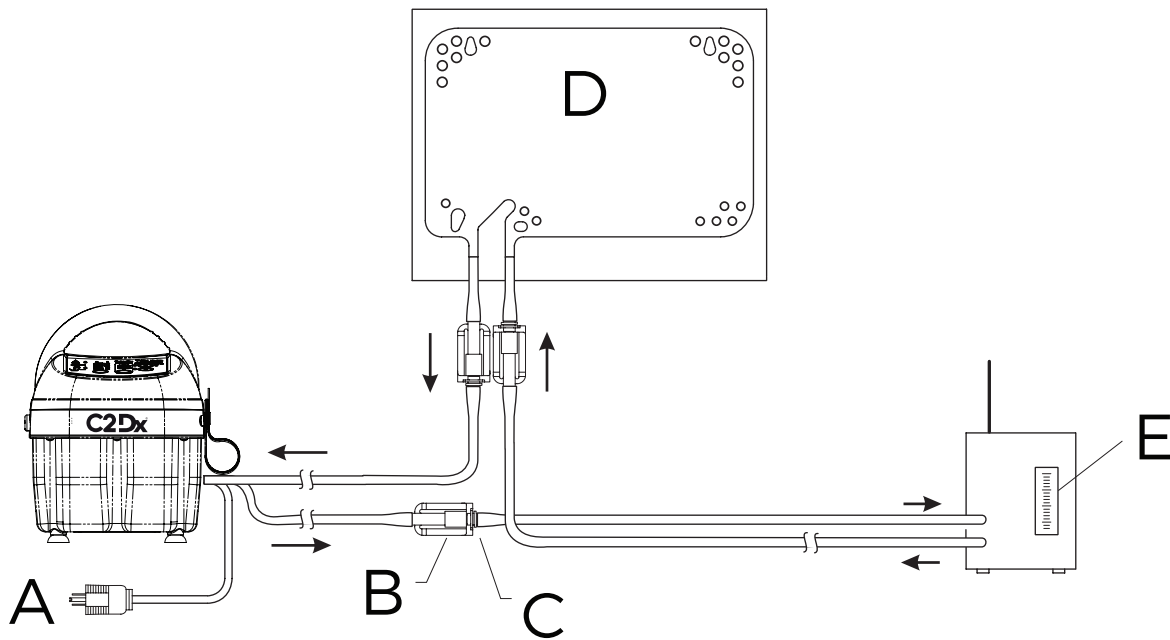

Figure 1: Functional check setup for **Clik-Tite®** connectors

1. Plug into a properly grounded outlet (A) ([Figure 1 on page 16](#)).
2. Fitting and tube closest to the front of the **T/Pump® Temperature Therapy Pump** (B).
3. Male **Clik-Tite® connectors** (black O-ring) (C).
4. **Mul-T-Pad® Temperature Therapy Pad**, size 18" or 22": lay the pad flat and at the same level as the pump (D).
5. **TPT9**, 7 gph (26.5 lph) minimum. Read at top of the float (E).

Functional check setup - Colder connection

Note: If the flow meter is connected in reverse, the flow meter will indicate no flow. Reverse the pump hose connections to change the direction of the flow.

Preventive maintenance

Functional checks (Continued)

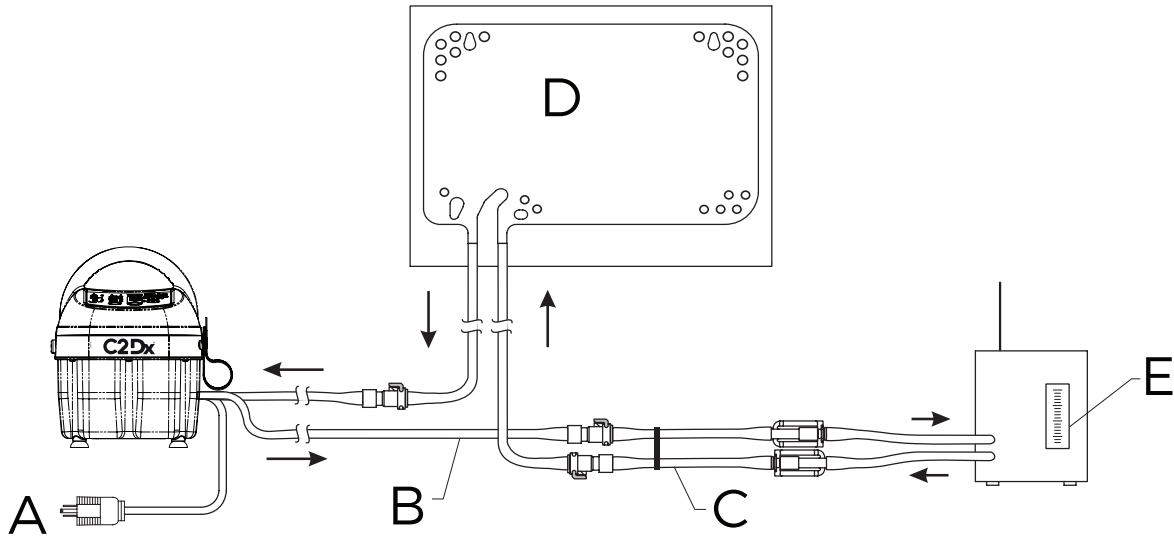

Figure 2: Functional check setup for Colder connector

1. Plug into a properly grounded outlet (A) ([Figure 2 on page 17](#)).
2. Fitting and tube closest to the front of the **T/Pump® Temperature Therapy Pump** (B).
3. Attach the Adapter hose assembly (C).
4. **Mul-T-Pad® Temperature Therapy Pad**, size 18" or 22": lay the pad flat and at the same level as the pump (D).
5. **TPT9**, 7 gph (26.5 lph) minimum. Read at top of the float (E).

Internal pump inspection

1. Unplug the product.
2. Using a #2 Phillips screwdriver, remove and save the 9 screws that secure the tray to the reservoir.
P/N 90018082 (x4) P/N 90018075 (x5)
3. Perform a visual inspection of all internal parts.
4. Remove any accumulated dirt with a vacuum cleaner or air compressor.
5. Reverse steps to reinstall.
6. Verify proper operation before returning the product to service.

Flow and operating temperature test

Note: Stay present for the full duration of the test to observe all readings and to prevent damage to the **T/Pump® Temperature Therapy Pump**.
Perform this test on a fully assembled unit.

1. Connect the **T/Pump® Temperature Therapy Pump** to the **TPT9** and **Mul-T-Pad® Temperature Therapy Pad** (see [Functional check setup - Clik-Tite® connectors on page 16](#) or [Functional check setup - Colder connection on page 17](#)).
2. Straighten the pad and hose.
3. Open the hose clamps.
4. Open the fill cap on top of the pump.

Preventive maintenance

Functional checks (Continued)

5. Fill with room temperature water to the Heating water line.
6. Plug the **T/Pump® Temperature Therapy Pump** into a properly grounded Hospital Grade receptacle.
Notes
 - The **T/Pump® Temperature Therapy Pump** performs a self test of the lights and audible alarm, with light pattern and short audible beep.
 - The **T/Pump® Temperature Therapy Pump** goes to Standby mode with only the Standby light on.
7. Press the On/Standby button.
8. Set the temperature to 107° F (42°C) and select Continuous Therapy Mode.
9. Allow the temperature to stabilize. Stabilization is indicated by a steady (not flashing) light at the temperature setpoint.
10. After stabilization, allow 5 minutes before proceeding. The **T/Pump® Temperature Therapy Pump** controls to 107° F \pm 2° F (42° C \pm 1°C) at the inlet to the pad for the duration of the test.
11. On the **TPT9**, take a temperature reading every 1/2 minute for 5 minutes, average the 10 readings and record the flow reading from the **TPT9**. Verify the average temperature is at 107° F \pm 2° F (42° C \pm 1°C) and flow is 7 gph (26.5 lph) minimum.

Notes

- If the **T/Pump® Temperature Therapy Pump** does not reach the temperature and flow, press the On/Standby button, unplug the unit, check the pad and hoses for kinks and start over.
12. Press the On/Standby button and unplug the unit.

Notes

- If at any time the Function test needs to be stopped, press the On/Standby button.

Backup limit thermostat test

This test is to make sure that the pad stays below a safe level in an over temperature condition.



Figure 3: Connection of test temperature sensor

1. Unplug the product.
2. Using a #2 Phillips screwdriver, remove and save the 9 screws that secure the tray to the reservoir.
P/N 90018082 (x4) P/N 90018075 (x5)
3. Unplug the Temperature Sensor.
4. Install the test probe (Figure 3 on page 18). Make sure that you position the test probe away from the motor fan.

Preventive maintenance

Functional checks (Continued)

5. Plug the **T/Pump® Temperature Therapy Pump** into a properly grounded Hospital Grade receptacle.

Notes

- The **T/Pump® Temperature Therapy Pump** performs a self test of the lights and audible alarm, with light pattern and short audible beep
- The **T/Pump® Temperature Therapy Pump** goes to Standby mode with only the Standby light on.

6. Press the On/Standby button. The **T/Pump® Temperature Therapy Pump** starts running at the default Setpoint of 100° F (38° C)

Notes: The Control and Over Temperature processor are reading the room temperature. The processor in turn supplies heat, to bring up the temperature past the setpoint. This will drive the water flowing through the system to a temperature that will trip the thermostat (in approximately 10 to 15 minutes).

7. Record the peak temperature read by the thermometer. The temperature recorded must be between 110° F (43.3° C) and 120° F (49° C).

Notes

- If the thermostat operates outside of its intended temperature range, it must be replaced.
- After the thermostat trips, the system will cool down to a temperature that resets the thermostat (in approximately 20 to 25 minutes). This Trip/Reset cycle will continue until the unit is put back into Standby mode.

8. Press the On/Standby button. The **T/Pump® Temperature Therapy Pump** goes into Standby mode.

9. Unplug the **T/Pump® Temperature Therapy Pump**.

10. Unplug the Test probe. Plug the Original Temperature Sensor back in.

11. Close the unit and reinstall the screws removed in steps 2 through 5.

12. Verify proper operation before returning the product to service.

Water leak check

1. After completing the backup limit thermostat test, tilt the product toward you so the front is down. Hold it in this position for 3 minutes.
2. Return the unit to the upright position.
3. Check the reservoir tray joint for water leaks.
4. Turn the product so that the back is facing you. Tilt the product toward you so the back is down. Hold it in this position for 3 minutes.
5. If a water leak is found, see service [Reservoir on page 26](#).

Ground resistance check

WARNING

Risk of electrical shock. Make sure that the product is unplugged when performing the ground resistance test.

- Using a ground resistance meter, measure the resistance between the ground pin on the plug and the brass manifold block, see [Figure 5 on page 25](#) item 6. You can access the ground through the hole where the hose connects to the pump (see [Figure 4 on page 20](#)).

Notes: The value should not be more than 0.5 ohm.

Preventive maintenance

Functional checks (Continued)

Current leakage check

Check the current leakage at this point with the unit full and connected to a pad.

Procedure:

1. Connect the pump to the **Mul-T-Pad® Temperature Therapy Pad**.
2. Straighten the pad and hoses.
3. Open the hose clamps.
4. Open the fill cap on top of the pump.
5. Fill with room temperature water to the Heating water line. Close the fill cap on the top of the pump.
6. Plug the pump into a properly grounded Hospital Grade receptacle.

Notes: The pump performs a self test of the lights and audible alarm, with a light pattern and a short audible beep. The pump goes to Standby mode with only the Standby light on.

7. Press the **On/Standby** button.
8. Using the Current leakage meter, measure all combinations of heater in the on and off states by pressing the **On/Standby** button.

Notes

- Access to ground for current leakage testing is available through the hole where (See [Figure 4 Access to ground on page 20](#)) the hose connects to the pump.
- The highest reading should be less than 100 μ A.



Figure 4: Access to ground

9. Record the highest reading.
10. Disconnect the current leakage meter.

Troubleshooting

Problem	Possible Cause	Solution
T/Pump® Temperature Therapy Pump will not turn on	<p>The electrical cord is NOT plugged into a properly grounded Hospital Grade receptacle.</p> <p>Damaged cord or plug</p> <p>Defective PC Board / Sensor</p> <p>Defective Membrane Panel</p>	<p>Insert the plug into the properly grounded Hospital Grade receptacle.</p> <p>Visually check the power cord for any defects. If defective, replace the power cord.</p> <p>Refer to T/Pump® Temperature Therapy Pump will NOT heat.</p> <p>Replace the Membrane Panel.</p>
T/Pump® Temperature Therapy Pump will not pump	<p>Water level is LOW or reservoir is EMPTY</p> <p>Loss of POWER to motor</p> <p>Defective Motor / Defective Impeller magnet or magnet driver assembly</p>	<p>Refill with room temperature water to proper level.</p> <p>Check the POWER (TP700 / TP700C - 120V ± 10%) across the motor connections. If present check for defective motor / defective impeller magnet or magnet driver assembly. If there is NO power, replace the PC Board.</p> <p>Replace the motor if the fan is NOT spinning when the unit is plugged in and in run mode. Otherwise, check the impeller for any obstruction or replace the Impeller magnet assembly.</p> <p>If the fan is spinning and there is no defect on the impeller magnet assembly, check the magnet driver assembly to see if the screw holding the driver magnet to the motor shaft is tight.</p>
Warning indicator on with unit in Standby Mode	Unit shut down in an OVER temperature condition	<p>Empty the reservoir and refill with room temperature water.</p> <p>Make sure all clamps are OPEN.</p> <p>Press the On/Standby button.</p> <p>Verify flow through the pad.</p> <p>The Warning light will turn OFF within 5 minutes.</p>
Temperature or Therapy Time buttons do not work	<p>The buttons have been LOCKED</p> <p>Defective Membrane Panel</p>	<p>Press and hold the lock button for two (2) seconds.</p> <p>Replace the Membrane Panel.</p>
Flow indicator and Standby indicator are ON with T/Pump® Temperature Therapy Pump NOT pumping	Unit detected a Flow warning for more than 5 minutes, thus goes to Standby	<p>Reference "Flow indicator light is ON"</p> <p>Correct the problem, and press the On/Standby to put the unit back into Run mode.</p>

Troubleshooting

Problem	Possible Cause	Solution
Flow indicator light is ON	Water flow to pad or hose is RESTRICTED Clamp is CLOSED Water level is low or reservoir is EMPTY T/Pump® Temperature Therapy Pump is filled with water that is too HOT	Straighten the hose Open the clamp Refill with room temperature water to proper level Refill with room temperature water to proper level
Warning indicator & Audible alarm (Flash / Beep)	A High Heat (107°F / 42°C) or Cooling Setpoint was selected (50°F / 10°C) Loss of Power while unit was in a Therapy mode. (Possible Power Fail) Unit is running after a 20- or 30-minute "OFF" Therapy Cycle period, has reached the desired Setpoint, and is now timing the 20- or 30- minute ON cycle period The unit just went into, or came out of Lock mode	Indication only: A Setpoint outside body temperature range is selected. Insert the plug fully into the receptacle, place the unit into Standby mode , then unplug the T/Pump® Temperature Therapy Pump . If Power is removed while unit is in On-Mode, the Power Fail alarm will beep for approximately 10 minutes. Indication only to indicate an "ON" Therapy Cycle period is timing. Indication only.
Both the Temperature and Therapy Cycle Setpoint lights are BLINKING	Unit is in "OFF" Therapy Cycle time	Indication only.
Temperature Setpoint light BLINKING	Unit is warming up to the selected Setpoint Unit is in Cooling mode , for longer than 40 minutes	Indication only. Follow the "shutdown" procedure. Drain the water in reservoir to ice fill level, and refill with ice. Follow the "start-up" procedure.
T/Pump® Temperature Therapy Pump will NOT Heat	Reservoir is EMPTY Flow is BLOCKED Therapy Cycle is OFF Heater is NOT receiving Power, or is defective	Refill with room temperature water to proper level Reference "Flow indicator light is ON" above Wait for Therapy Cycle ON Check if the Set Point is set too low. Remove cover and check Power (TP700 / TP700C - 120V ± 10%) to the heater at J2 on the PCB. NOTE: Power to J2 cycles ON and OFF If Power is present and thermostat is CLOSED, heater is probably defective. Cold heater resistance is approximately 49 ohms (120V). Replace heater if required. Perform Functional checks on page 14 . If Power is present and thermostat is OPEN, thermostat is probably

Troubleshooting

Problem	Possible Cause	Solution
		defective. Replace thermostat if it does not pass Backup Limit Thermostat Test from Functional check. If there is NO Power to the heater, replace the PC Board .
T/Pump® Temperature Therapy Pump will NOT Cool	Reservoir is EMPTY Flow is BLOCKED Ice is DEPLETED	Refill with room temperature water to proper level Reference "Flow indicator light is ON" section Drain excess water to Cooling water line and fill remainder of reservoir with ice.
Water LEAKS from hose connectors		Replace Clik-Tite® connector Male: P/N: 03887001 Female P/N: 03884001 Snap Clik-Tite® connector SHUT Secure pad connection to pump (See quick disconnects). Replace connectors or pad if defective.

Wiring diagram

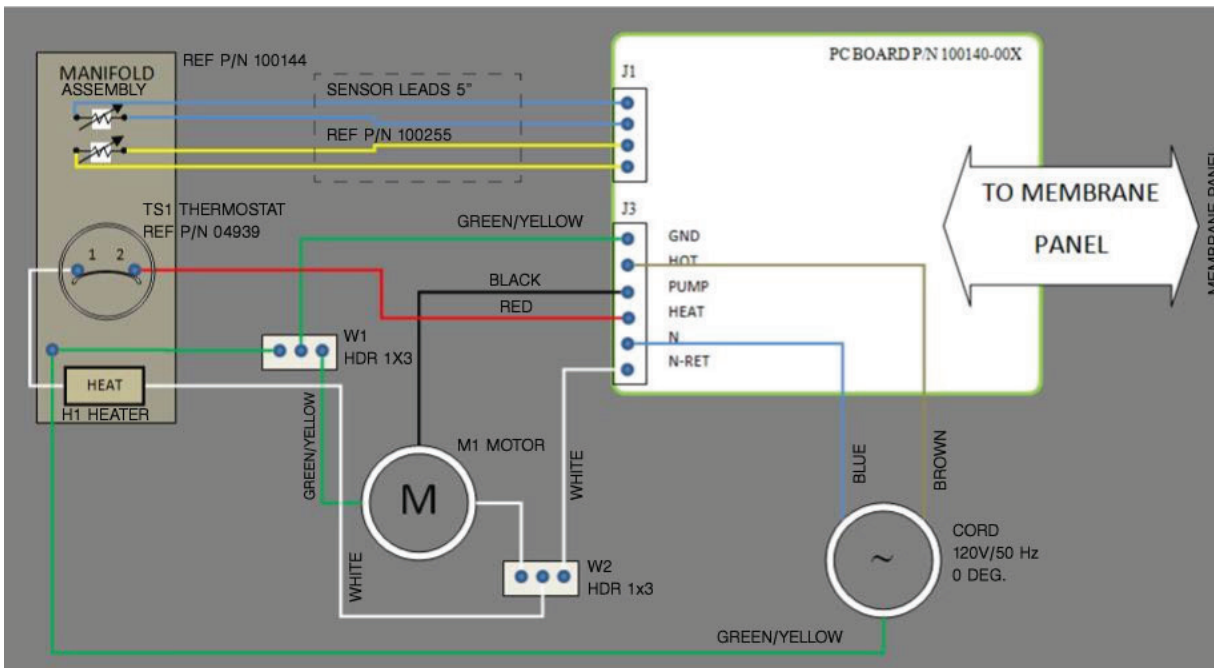

Service

Protecting against Electrostatic Discharge (ESD)

CAUTION

- Always use ESD protective equipment before opening antistatic bags and servicing electronic parts.
- Do not place unprotected circuit boards on the floor.

Note: Always ship back circuit boards to C2Dx® in the same antistatic bags that the new boards were originally shipped in.

The electronic circuits in the product are completely protected from static electricity damage when factory assembled. Always use adequate static protection when servicing the electronic systems of the product. All service personnel must use static protection whenever they are touching wires.

Sample antistatic protection equipment includes:

- 1 antistatic wrist strap
- 1 grounding plug
- 1 test lead with a banana plug on one end and an alligator clip on the other end

Make sure that you follow the ESD manufacturer's instructions for appropriate protection against static discharge.

Water temperature control

There are three devices that control the operation of the **T/Pump® Temperature Therapy Pump** heater:

- The temperature is thermistor controlled ([Theory of operation on page 25](#) item 8). This temperature is selectable from the operator's keypad ([Theory of operation on page 25](#) item 10). To prevent unauthorized temperature setting changes, a lockout key is available on the TP700 / TP700C "Professional" model.
- The limit thermostat ([Theory of operation on page 25](#) item 2) is on the brass manifold block ([Theory of operation on page 25](#) item 6). This thermostat senses water temperature flowing to the pad. If the water temperature exceeds specific limits (120° F), the thermostat will shut off the heater. The purpose of the limit thermostat is to prevent the pump from providing water at too high a temperature to the pad.
- The control of the selected temperature is performed by a dual thermistor ([Theory of operation on page 25](#) item 1) Dual Processor design. The Control Processor reads its thermistor and determines if heat is positive. If the reading is positive for heat, the Control Processor sends a signal to an Over Temperature Processor. The Over Temperature Processor reads the thermistor. This is to make sure that the temperature is below the over temperature value, before it allows the heater ([Theory of operation on page 25](#) item 5) to turn on.

Fluid system

The pump is a sump configuration. It is magnetically coupled to an impedance protected, shaded pole AC Motor ([Figure 5 on page 25](#) item 3).

The machine return hose fitting ([Figure 5 on page 25](#) item 7) is internal to act as an opening. This maintains a back pressure in the pad to make it resistant to flow restrictions.

Service

Theory of operation

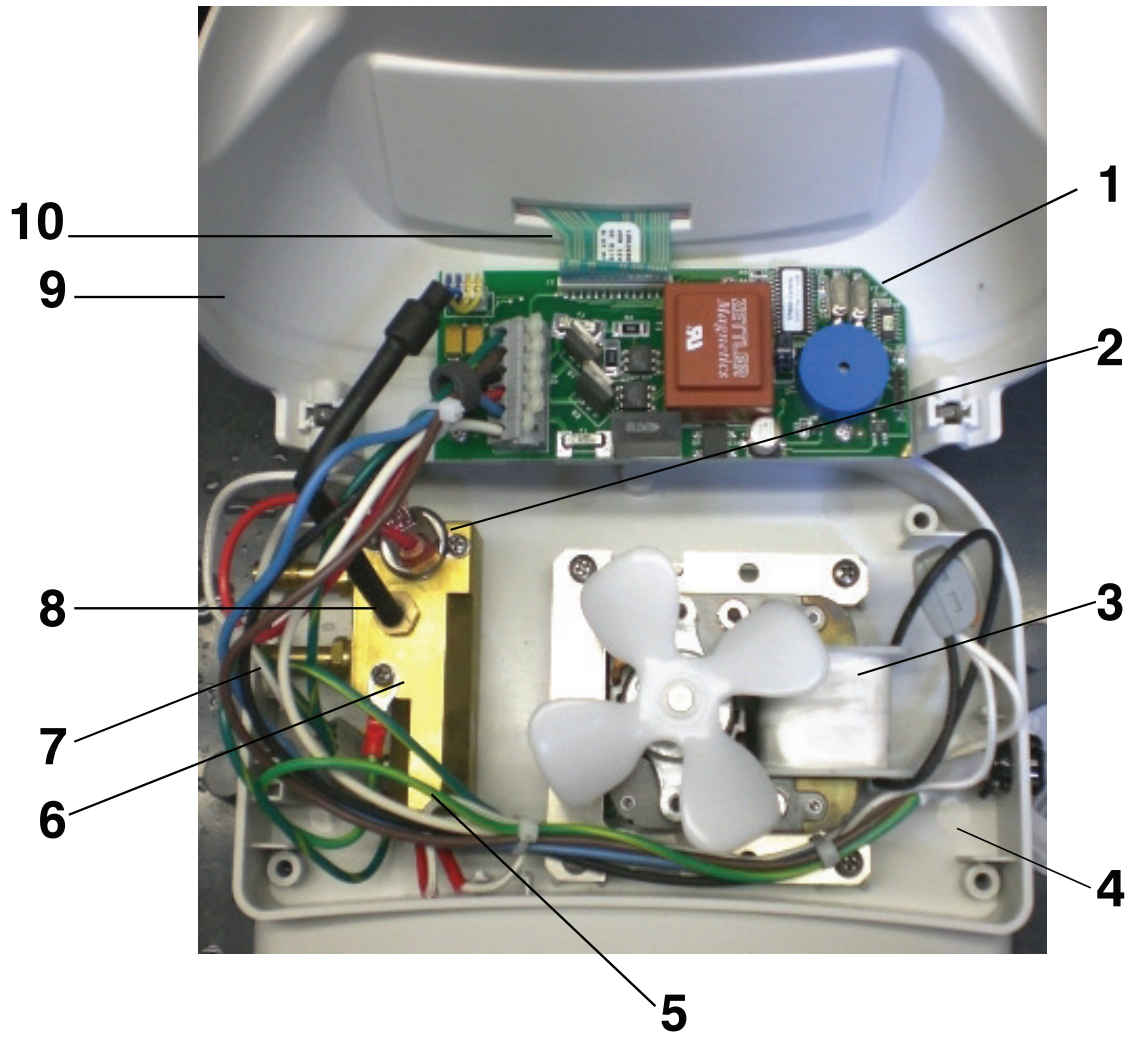

Figure 5: T/Pump® Temperature Therapy Pump service items

1	PC board (temperature controller)	6	Brass manifold block
2	Manifold backup limit thermostat	7	Return hose fitting
3	Pump motor	8	Temperature sensor
4	Tray assembly	9	Housing front assembly
5	Cartridge heater	10	Ribbon to front keypad

Reservoir

Tools required:

- #2 Phillips screwdriver

Procedure:

1. Unplug the product.
2. Drain the water out of the reservoir.
3. Using a #2 Phillips screwdriver, remove and save the 9 screws that secure the tray to the reservoir. P/N 90018082 (x4) P/N 90018075 (x5). Save the screws and the tray assembly.
Keep the upper housing with the tray. The upper housing has wires that connect the two parts.
4. Reverse steps to reinstall.
5. Verify proper operation before returning the product to service.

Upper front and rear housing

Tools required:

- #2 Phillips screwdriver

Procedure:

1. Unplug the product.
2. Drain the water out of the reservoir.
3. Using a #2 Phillips screwdriver, remove and save the 9 screws that secure the tray to the reservoir. P/N 90018082 (x4) P/N 90018075 (x5). Save the screws and the tray assembly.
4. Using a #2 Phillips screwdriver, remove the four screws from the back of the upper housing handle. Save the screws.
5. Remove and discard the upper or rear front housing assembly.
6. Reverse steps to reinstall.
7. Verify proper operation before returning the product to service.

PC Board

Tools required:

- #2 Phillips screwdriver

Procedure:

1. Using ESD Protection, Unplug the product.
2. Drain the water out of the reservoir.
3. Using a #2 Phillips screwdriver, remove and save the 9 screws that secure the tray to the reservoir. P/N 90018082 (x4) P/N 90018075 (x5). Save the screws and the tray assembly.
4. Using a #2 Phillips screwdriver, remove the four screws from the back of the upper housing handle. Save the screws and upper housing handle.
5. Lift the Upper Front Housing from the Tray assembly.
6. Remove the Keypad Ribbon cable ([Figure 5 on page 25](#), item 10) from the PC Board ([Figure 5 on page 25](#), item 1).
7. Remove the Temperature Sensor ([Figure 5 on page 25](#), item 8) from the PC Board.
8. Remove the six wires from the PC Board.
9. Remove the three screws from the PC Board.
10. Remove and discard the PC Board.

Service

11. Reverse steps to reinstall.
12. Verify proper operation before returning the product to service.

Heater kit assembly

Tools required:

- #2 Phillips screwdriver

Procedure:

1. Unplug the product.
2. Drain the water out of the reservoir.
3. Using a #2 Phillips screwdriver, remove and save the 9 screws that secure the tray to the reservoir. P/N 90018082 (x4) P/N 90018075 (x5). Save the screws and the tray assembly.
4. Using a #2 Phillips screwdriver, remove the four screws from the back of the upper housing handle. Save the screws and upper housing handle.
5. Remove the two wires from the Cartridge Heater. One goes to the PC Board, the other goes to a neutral wiring connector.
6. Remove the Temperature Sensor ([Figure 5 on page 25](#), item 8) from the Brass Heater Manifold.
7. Cut the Gray Hose connected to the Brass Heater Manifold.
8. Remove the two brass fittings on the bottom of the Tray assembly which hold the brass manifold block to the tray.
9. Discard the two O-rings between the brass heater manifold and the tray assembly.
10. Remove and discard the heater kit assembly.
11. Reverse steps to reinstall.
12. Verify proper operation before returning the product to service.

Heater assembly

Tools required:

- #2 Phillips screwdriver

Procedure:

1. Perform the steps for the Upper Front and Rear Housing.
2. Remove the two wires from the Cartridge Heater. One goes to the PC Board, the other goes to a neutral wiring connector.
3. Remove the two brass fittings on the bottom of the Tray assembly that hold the brass manifold block to the tray.
4. Pay special attention when reassembling the following:
 - a. Gray hose can be placed in warm water (<50 °C) to facilitate installation on manifold fittings.
 - b. All O-rings must be seated. The reservoir O-ring is shaped. The shape must be aligned with the reservoir.
 - c. All fittings on the manifold should have Teflon tape applied to prevent leaks.
 - d. Make sure wires are routed away from the cooling fan blades.
 - e. For proper screw size and location for reservoir and housing, refer to parts illustration and replacement parts list.
 - f. Transfer the serial number to the new reservoir and cover the serial number label window

Service

- g. When needed, route the membrane ribbon (A) to the PCB Kit (B) from the Front Housing (C) (Figure 6 on page 28). This prevents interference between the ribbon and moving components..

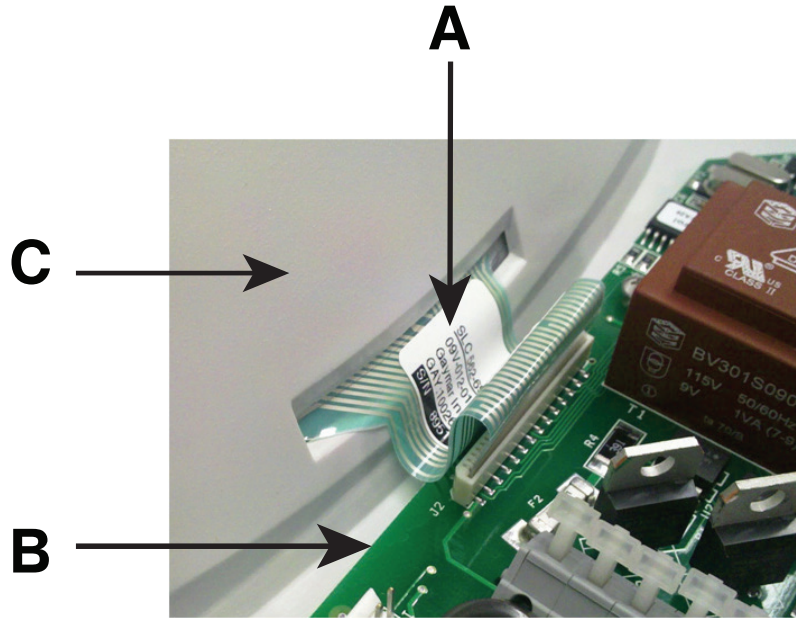
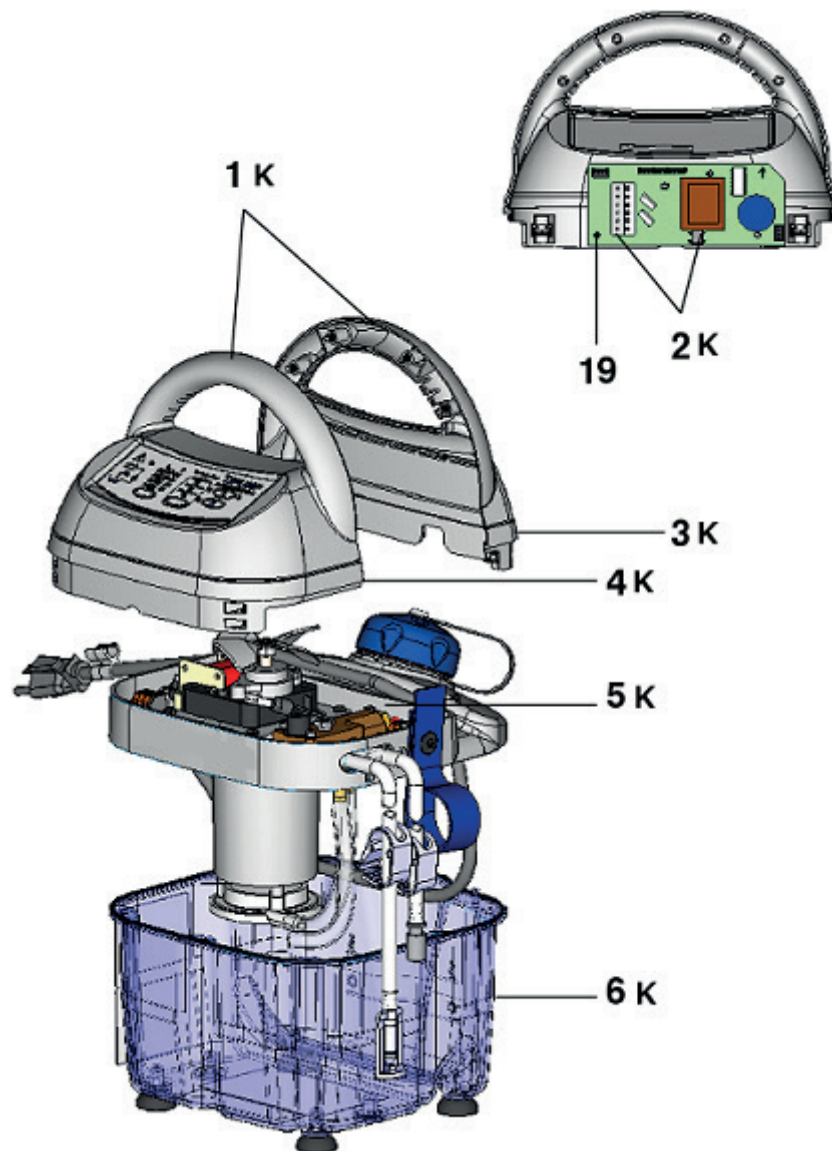

Figure 6: Ribbon cable

5. Verify proper operation before returning the product to service.

T/Pump® Temperature Therapy Pump assembly



T/Pump® Temperature Therapy Pump assembly

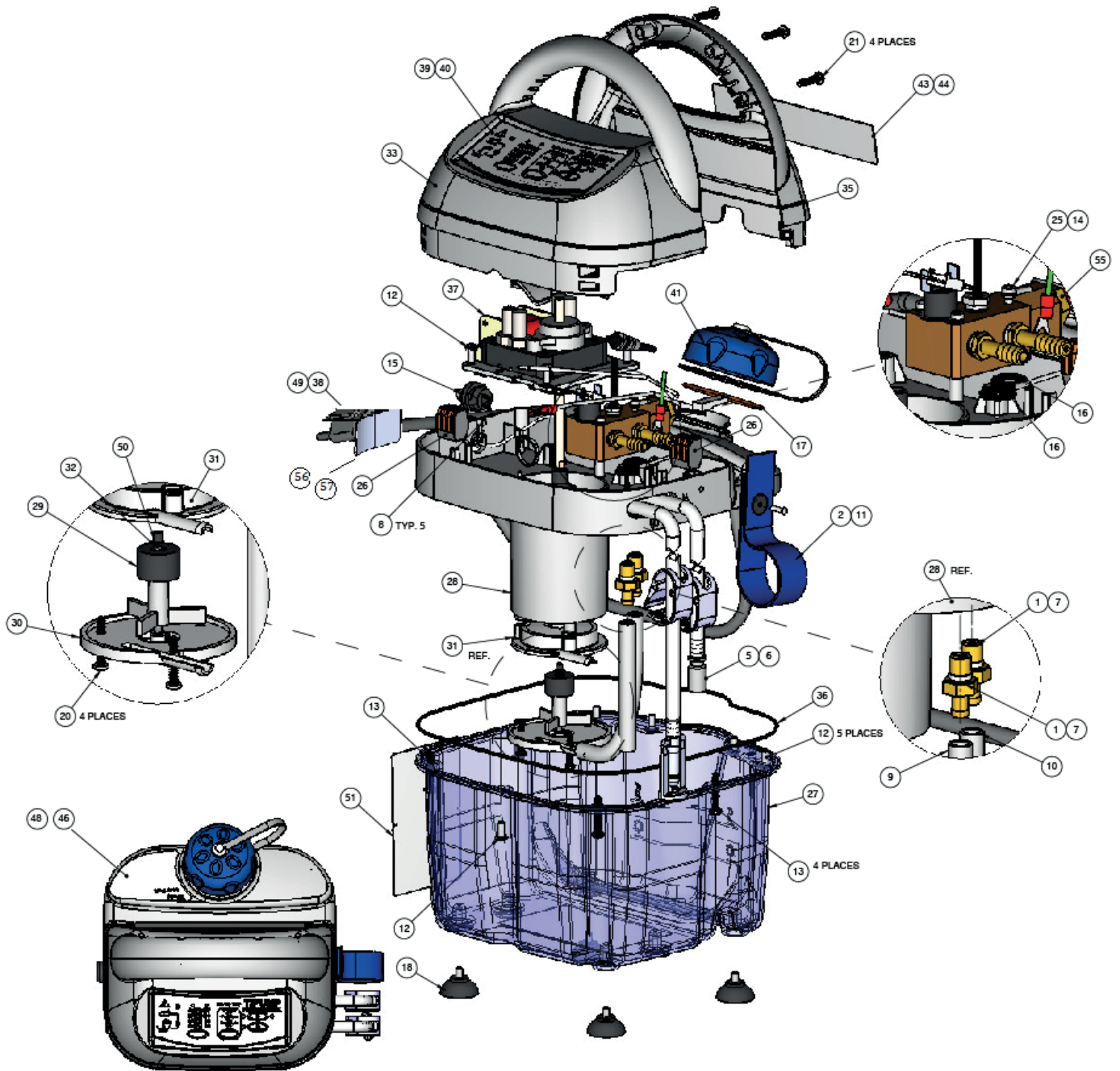

T/Pump® Temperature Therapy Pump assembly

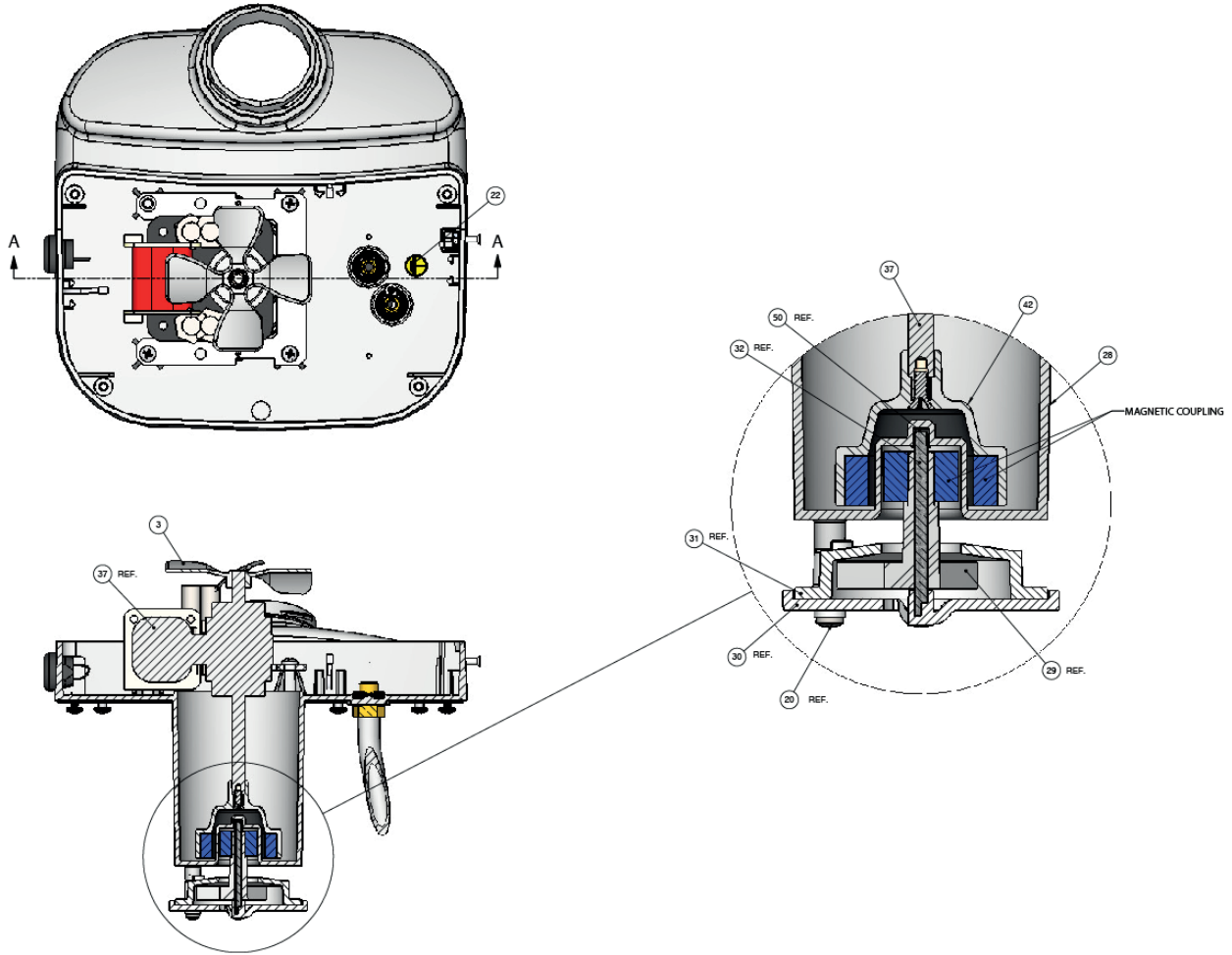

Item	Number	Name	Quantity
1K	100822001	KIT: Upper front & Rear Housing. Includes both Front & Rear plastic housing, Label, Membrane Panel (TP700 / TP700C)	1
2K	100898000	KIT: PC Board/Sensor Assembly - This assembly comes with a pre-calibrated sensor and PCB assembly. They are a match set. Do not use the old sensor with the new PC Board or the old PC Board with the new sensor (TP700 / TP700C)	1
3K	100819001	KIT: Upper Rear Housing Assembly. Includes Rear Plastic Housing with Label (TP700 / TP700C)	1
4K	100818001	KIT: Upper Front Housing Assembly. Includes Front Plastic Housing with Membrane Panel (TP700 / TP700C)	1
5K	100821001	KIT: Heater Assembly. Includes Brass Manifold, 2 O-Rings, 4 Fittings. (TP700 / TP700C)	1
6K	100820000	KIT: Reservoir Assembly. Includes Reservoir, Gasket, Rubber Feet, Label.	1
1	03394000	Fitting, manifold	2
2	03791001	Strap assembly - hose	1
3	04152000	Fan	1

T/Pump® Temperature Therapy Pump assembly

Item	Number	Name	Quantity
5	08086000	Hose assembly - Clik-Tite® Connectors	1
6	08648000	Hose assembly - Colder	1
8	50522006	Ty-Wrap, self locking	5
9	81002028	Tubing, PVC, panacea 1/4 ID x 3/8 OD x 3 1/2" LG	1
10	81002048	Tubing, PVC, panacea 1/4 ID x 3/8 OD x 6" LG	1
11	90018029	Screw, machine 4-40 x 1/2" flat head Phillips	1
12	90018075	Screw machine pan head CR 8-32 UNC 2A x 3/8 LG S	9
13	90018082	Screw, machine pan head #8-32 x 1 SST	4
14	90049005	Lock washer, spring #6 SST	4
15	90076018	Bushing, straight thru	1
16	90295019	O-Ring	2
17	90295020	O-Ring, silicone	1
18	90385000	Cup, suction	4
19	90514003	Screw type "BT" thread cutting pan HD SST. #4 x 5/16" LG	3
20	90514013	Screw type "BT" thread cutting pan HD SST. #6 x 7/8" LG	4
21	90514020	Screw type "BT" thread cutting #8 x 3/4" LG	4
22	90603000	Label ground identification	1
23	91275059	Screw, machine, flat C'Sunk HD, CR SST 6-32 x 3/8 LG	1
24	91390000	Toroid, ferrite ring	1
25	91454052	Screw, machine, fillister head #6-32 x 1/4 LG SST	1
26	100092000	Connector lever nut 3 terminal	2
27	100127000	Reservoir	1
28	100129000	Tray assembly	1
29	101157000	Impeller/magnet assembly	1
30	100132000	Impeller housing bottom	1
31	100133000	Impeller housing top	1
32	100134000	Pin, impeller	1
33	100139000	Housing, front assembly	1
35	100142000	Housing, rear assembly	1
36	100152000	O-Ring, reservoir	1
37	100261000	Motor/plate assembly	1
38	100267000	Cord, power assembly (gray)	1
39/40	100269001	Membrane panel - professional	1
41	100275000	Cap, tethered, rivet assembly	1
42	101158000	Magnet driver assembly	1
43/44	100288001	Label, instruction professional	1

T/Pump® Temperature Therapy Pump assembly

Item	Number	Name	Quantity
46	100289001	Label, ratings professional	1
48	100289003	Label, ratings professional with colder style	1
49	100292000	Clip, cord	1
50	100378000	Cap (for Impeller Pin)	1
51	100578000	Label, danger	1
52	100706000	Wiring harness	1
53	100706001	Wiring harness	1
54	100706002	Wiring harness	1
55	100144000	Heater assembly - classic 120V/ 60Hz	1
56	0000-001-083	Label, product barcode TP700C	1
57	0000-001-084	Label, product barcode TP700	1

Your Distributor is:
Braintree Scientific, Inc.
PO Box 850498, Braintree, MA 02185
781-917-9526
Email: Info@braintreesci.com
Web: www.braintreesci.com