

Multi-Phaser™
Model: BS-500 / BS-501
BS-1000 Family of Programmable Syringe Pumps

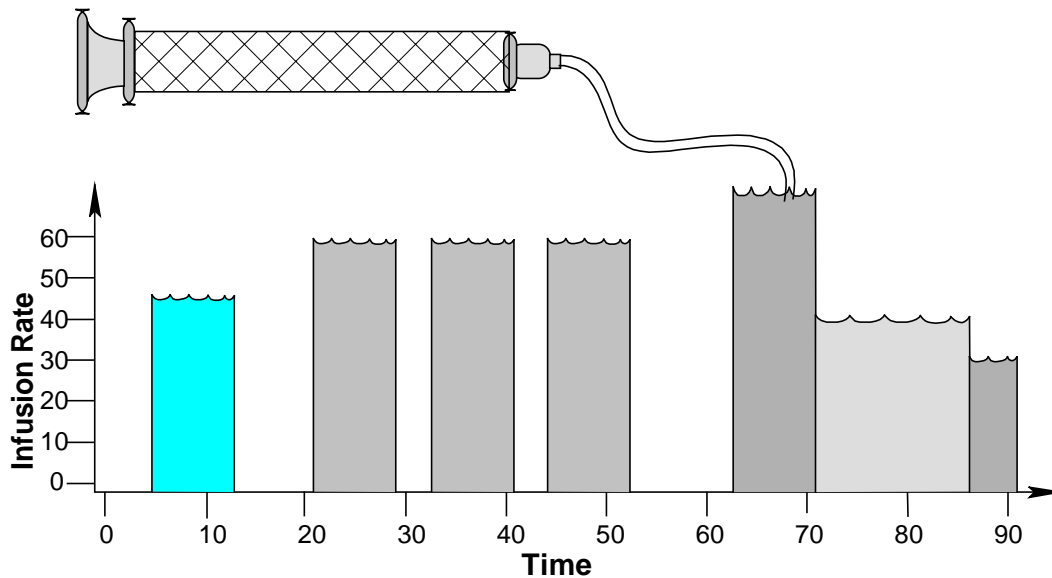

“WHAT’S YOUR APPLICATION?”™

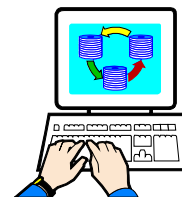

WARNING
NOT FOR CLINICAL
USE ON HUMANS

Quick Start Instructions

Assumes that the pump was not previous programmed with a multiple Phase Pumping Program.

- Plug in the pump.
- Attach the computer cable to the "Computer" connection on the RJ-11 connector
- Start the terminal emulator program on the computer
 - Baud Rate: 19,200
 - Data frame: 8N1
- Note: Each command sent to the pump must have a carriage return (0x0D) at the end, but space characters are optional and will be ignored.
- Note: Wait for the response from each command before sending the next command

Setup Pumping Parameters

Set the Syringe Inside Diameter:

- Where "nn.nn" is the syringe inside diameter: Send the command: DIA nn.nn

Set the Pumping Rate.

- Where "nn.nn" is the pumping rate and "xx" is the rate's units: Send the command: RAT nn.nn xx

Rate units	"xx" value
mL/hr	MH
µL/hr	UH
mL/mn	MM
µL/mn	UM
- If the pumping rate is out of range the response message to the computer will include "?OOR"

Set the Volume to be Dispensed or Continuous Pumping

- Where "nn.nn" is the volume to be dispensed, send the command: VOL nn.nn
 - If the volume to be dispensed is 0, then the pump will pump continuously.
- Note: The units for the volume to be dispensed will be mL or µL, depending on the syringe size.
 - At or below 14.00 mm syringe diameter, volume units are µL
 - Above 14.00 mm syringe diameter, volume units are mL

Set the Pumping Direction

- For infusion, send the command: DIR INF
- For Withdrawal, send the command: DIR WDR

Load the Syringe

- Press in the white drive-nut button to move the pusher block.
- Insert the syringe plunger in the pusher block slot.
- Insert the syringe barrel flange in the flange brackets with the syringe barrel holder on the syringe. Tighten the flange brackets onto the syringe flange. Tighten the pusher block screw.

Operating the Pump

Start the Pump: Send the command: RUN

Stop the Pump: Send the command: STP



Query the Pump Status

- Send just a carriage return to the pump. The pump will respond with a status prompt

When Pumping

- The pumping rate can be changed.
- With continuous pumping, the pumping direction can be changed.

PUMP RESET: Send the command: *RESET

1.	<u>GENERAL INFORMATION.....</u>	<u>1</u>
1.1	WARNINGS  AND CAUTIONS 	1
1.2	DISCLAIMER.....	1
1.3	WARRANTY	2
2.	<u>OVERVIEW</u>	<u>2</u>
2.1	GLOSSARY OF TERMINOLOGY AND CONCEPTS.....	3
3.	<u>SETUP</u>	<u>5</u>
4.	<u>LOADING SYRINGES.....</u>	<u>5</u>
5.	<u>OPERATION.....</u>	<u>6</u>
5.1	SYRINGE INSIDE DIAMETER.....	6
5.1.1	DEFAULT VOLUME UNITS	6
5.2	START/STOP TRIGGERS.....	6
5.3	OPERATING THE PUMP.....	6
5.4	PUMPING RATE.....	6
5.4.1	CHANGING THE PUMPING RATE AND DIRECTION WHILE PUMPING	7
5.5	PUMPING DIRECTION	7
5.6	DISPENSE VOLUME TARGET AND CONTINUOUS PUMPING.....	7
5.7	VOLUME DISPENSED.....	7
5.8	RESUMING WHEN PAUSED.....	7
5.9	PUMP STALLED	8
6.	<u>SETUP CONFIGURATION</u>	<u>8</u>
6.1	RS-232 PUMP NETWORK CONFIGURATION.....	8
6.2	POWER FAILURE MODE	9
6.3	AUDIBLE ALARM ENABLE.....	9
6.4	TTL I/O OPERATIONAL TRIGGER CONFIGURATION.....	9
6.5	TTL I/O DIRECTIONAL CONTROL INPUT CONFIGURATION	9
6.6	PUMP MOTOR OPERATING TTL OUTPUT CONFIGURATION.....	10
7.	<u>PUMPING PROGRAM.....</u>	<u>10</u>
7.1	HOW TO ENTER PUMPING PROGRAMS	10
7.2	CLEARING THE PUMPING PROGRAM.....	11
7.3	PROGRAM FUNCTION DESCRIPTIONS	11
7.3.1	RATE FUNCTION	11

7.3.2	INCREMENT RATE FUNCTION	11
7.3.3	DECREMENT RATE FUNCTION	11
7.3.4	STOP PUMPING OPERATION AND END THE PROGRAM	11
7.3.5	JUMP TO PHASE FUNCTION	11
7.3.6	DEFINE STARTING PHASE OF LOOP FUNCTION	12
7.3.7	DEFINE CONTINUOUS LOOP END FUNCTION	12
7.3.8	DEFINE LOOP END AND LOOP REPETITIONS FUNCTION	12
7.3.9	PAUSE PUMPING FUNCTION	12
7.3.10	JUMP TO PHASE IF EXTERNAL TRIGGER FUNCTION	13
7.3.11	SETUP EVENT TRIGGER JUMP PHASE FUNCTION	13
7.3.12	'ES:NN': SETUP EVENT SQUARE WAVE TRIGGER JUMP PHASE	13
7.3.13	EVENT RESET FUNCTION	13
7.3.14	SET TTL OUTPUT PIN FUNCTION	13
7.3.15	BEEP FUNCTION	13
7.4	PUMPING PROGRAM EXAMPLES	14
7.4.1	EXAMPLE 1: 2 STEP RATE	14
7.4.2	EXAMPLE 2: REPEATED DISPENSES WITH SUCK BACK	14
7.4.3	EXAMPLE 3: RAMPING THE FLOW RATE	15
7.4.4	EXAMPLE 4: COMPLEX DISPENSES WITH EXTERNAL SYNCHRONIZATION	16
7.4.5	EXAMPLE 5: CONTROL FROM A HIGH-LOW PRESSURE SENSOR	17
7.4.6	EXAMPLE 6: AUTOMATED DISPENSING WITH SYNCHRONIZATION	19
7.4.7	EXAMPLE 7: DISPENSING WITH COMPLEX SYNCHRONIZATION	20
8.	<u>RS-232 COMMUNICATIONS.....</u>	<u>22</u>
8.1	CONNECTION AND NETWORKING	22
8.2	RS-232 PUMP NETWORK CONFIGURATION	22
8.3	RS-232 PROTOCOL	22
8.3.1	RS-232 GENERAL SYNTAX LEGEND	23
8.3.2	RS-232 PROTOCOL: BASIC MODE	24
8.3.3	RS-232 PROTOCOL: SAFE MODE	24
8.3.4	RS-232 PROTOCOL: BASIC AND SAFE MODE COMMON SYNTAX	25
8.3.5	NETWORK COMMAND BURST	25
8.4	COMMAND ERRORS AND ALARMS	26
8.5	RS-232 COMMAND SET	26
8.5.1	PROGRAM FUNCTION COMMANDS	27
8.5.2	PUMP OPERATIONAL COMMANDS	29
8.5.3	CONFIGURATION AND SETUP COMMANDS	30
8.5.4	GENERAL CONTROL AND STATUS COMMANDS	31
8.6	GETTING STARTED WITH RS-232	32
9.	<u>LOGIC INTERFACE: TTL INPUT AND OUTPUT</u>	<u>33</u>
9.1	TTL I/O OPERATIONAL CONTROLS	34
9.2	TTL I/O CONTROL FROM THE PUMPING PROGRAM	35
9.3	TTL I/O CONTROL FROM RS-232	35
10.	<u>APPENDIX</u>	<u>36</u>

10.1 SYRINGE DIAMETERS AND RATE LIMITS 36
10.2 RS-232 COMMAND SUMMARY 37
10.3 RS-232 PUMP NETWORK CONNECTOR WIRING..... 38
10.4 ACCESSORIES 38
 10.4.1 ANA-BOX..... 38
 10.4.2 SYRINGE HEATER 38
 10.4.3 RS-232 NETWORK CABLES 38
 10.4.4 AUTOMATION CABLE: RECIPROCATING/DUAL PUMPS CONTROL CABLE 38
 10.4.5 VALVE CONTROLLER 39
 10.4.6 FOOT SWITCH..... 39
 10.4.7 FIRMWARE UPGRADE 39
10.5 TROUBLESHOOTING AND MAINTENANCE 39
10.6 SPECIFICATIONS..... 40
 10.6.1 MECHANICAL & ELECTRICAL..... 40
 10.6.2 OPERATIONAL 40
10.7 CUSTOM APPLICATIONS 40

1. General Information

Thank you for purchasing the NE-500 / NE-501 OEM Programmable Syringe Pump. With the NE-500 / NE-501 syringe pump, you will be able to perform simple infusions or implement a complex automated dispensing system.

Please familiarize yourself with the NE-500/501's operation by reading this user's manual. For future reference, record the serial number, located on the rear of the pump, and the date of purchase.

New Era Pump Systems can be contacted at:

2517 Bayview Ave.

Wantagh, NY 11793-4305













USA

Phone: (631) 249-1392 FAX: (707) 248-2089 Email: INFO@SYRINGEPUMP.COM

WWW.SYRINGEPUMP.COM

This Operating Manual, and the NE-500/NE-501's hardware, electronics and firmware are copyrighted. **Copyright 2004-2005, all rights reserved.**

1.1 Warnings and Cautions

-  Read the user's manual
-  No user serviceable parts are inside.
-  Disconnect power from the pump when connecting or disconnecting cables.
-  Do not immerse the pump in liquid
-  Install on a stable surface.
-  Keep hands and loose clothing away from the pumps moving parts.
-  The pump can automatically start when the Pumping Program is operating or when attached to an external control device.
-  Prevent liquids from entering openings of the pump.
-  Do not push objects of any kind into the chassis openings, except for appropriate cables and connectors.
-  If the pump becomes damaged, do not use unless certified safe by a qualified technician. Damage includes, but is not excluded to, frayed cords and deterioration in performance.
-  Discharge static from control cables before connecting by touching the cable to ground.
-  Before touching the pump, discharge static by touching ground.

1.2 Disclaimer

New Era Pump Systems Inc. makes no representations or warranties, expressed, statutory or implied, regarding the fitness or merchantability of this product for any particular purpose. Further, New Era Pump Systems Inc. is not liable for any damages, including but not limited to, lost profits, lost savings, or other incidental or consequential damages arising from ownership or use of this product, or for any delay in the performance of its obligations under the warranty due to causes beyond its control. New Era Pump Systems Inc. also reserves the right to make any improvements or modifications to the product described in this manual at any time, without notice of these changes.

New Era Pump Systems Inc. products are not designed, intended, or authorized for use in applications or as system components intended to support or sustain human life, as a clinical medical device for humans, or for any application in which the failure of the product could create a situation where personal injury or death may occur.

All brand and product names used in this manual are the trademarks of their respective owners.

1.3 Warranty

New Era Pump Systems Inc. warrants this product, and accessories for a period of two year, parts and labor, from the date of purchase. The repaired unit will be covered for the period of the remainder of the original warranty or 90 days, whichever is greater.

A return authorization number must be obtained from New Era Pump Systems Inc. before returning a unit for repair. Warranty covered repairs will not be performed without a return authorization number. At the option of New Era Pump Systems Inc., a defective unit will be either repaired or replaced.

This warranty does not cover damage by any cause including, but not limited to, any malfunction, defect or failure caused by or resulting from unauthorized service or parts, improper maintenance, operation contrary to furnished instructions, shipping or transit accidents, modifications or repair by the user, harsh environments, misuse, neglect, abuse, accident, incorrect line voltage, fire, flood, other natural disasters, or normal wear and tear. Changes or modifications not approved by New Era Pump Systems Inc. could void the warranty.

The foregoing is in lieu of all other expressed warranties and New Era Pump Systems Inc. does not assume or authorize any party to assume for it any other obligation or liability.

2. Overview

The NE-500/NE-501 is a general purpose single syringe pump capable of infusion and withdrawal. It is controlled from a microcontroller based system which drives a step motor, allowing a large range of pumping rates calibrated to the inside diameter of the loaded syringe. The syringe is driven from a drive-screw and drive-nut mechanism.

Features:

- ◆ Infusion and withdrawal pumping of syringes up to 60 cc.
- ◆ Pumping rates from 0.73 $\mu\text{l/hr}$ with a 1 cc to 2120 ml/hr with a 60 cc.
- ◆ NE-501 only: Stall detection: Automatically stops pump when pumping is impeded
- ◆ Infusion and withdrawal volumes separately accumulated.
- ◆ Programmable dispense volumes.
- ◆ Non-volatile memory of all operating parameters and Pumping Program
- ◆ Programmable Phases allowing complex pumping applications and interaction with external devices.
- ◆ RS-232 bi-directional control.
- ◆ Built-in pump network driver. Pump network supports up to 100 pumps and other devices.
- ◆ Two modes of RS-232 control, Basic and Safe. Safe mode provides communication error detection, loss of communication detection, and automatic transmitting of alarm conditions.
- ◆ TTL I/O with software filtered control inputs to eliminated glitches and ringing on the control inputs.
- ◆ Configurable TTL operational trigger.
- ◆ Power Failure Mode: Restarts the Pumping Program after a power interruption.
- ◆ Audible Alarm

2.1 Glossary of Terminology and Concepts

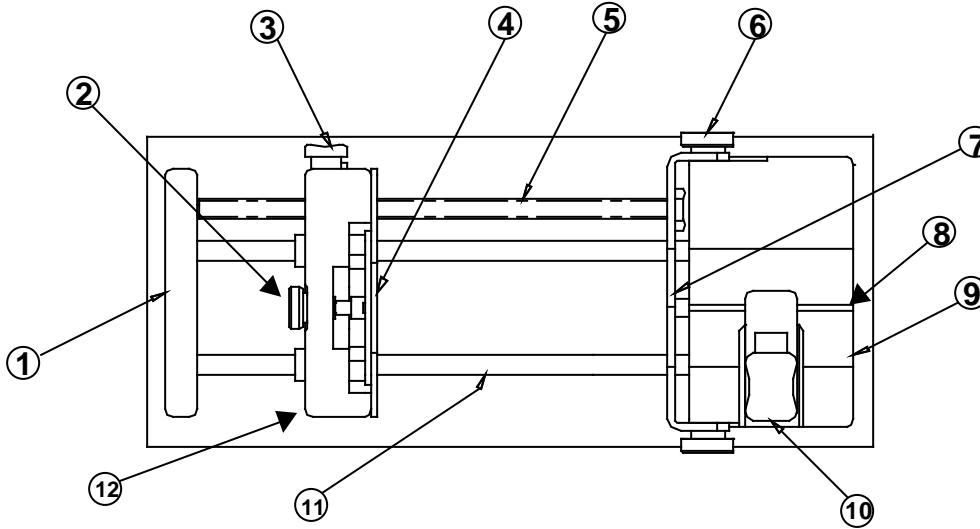

When a device has as many features as the NE-500/NE-501, understanding its operation could be a daunting task at first. By understanding the key concepts and terminology used in this manual, the operation of the NE-500/NE-501 will become quite intuitive. Every effort has been made to design the NE-500/NE-501 with a consistent and intuitive user interface.

To facilitate and enhance your understanding of the NE-500/NE-501's operation, please take the time to familiarize yourself with the basic concepts below:

Parts of the Pump

- | | |
|--|---------------------------------------|
| 1) End Plate | 7) Syringe Retainer Bracket |
| 2) Anti-Siphon Plate Adjustment Knob | 8) 'V' Slot (on Syringe Holder Block) |
| 3) Drive-Nut Button | 9) Syringe Holder Block |
| 4) Anti-Siphon Plate | 10) Syringe Holder Clamp |
| 5) Drive-Screw | 11) Guide Rod (2 guide rods) |
| 6) Syringe Retainer Thumbscrew (2, one on each side) | 12) Pusher Block |

Parts of a Syringe

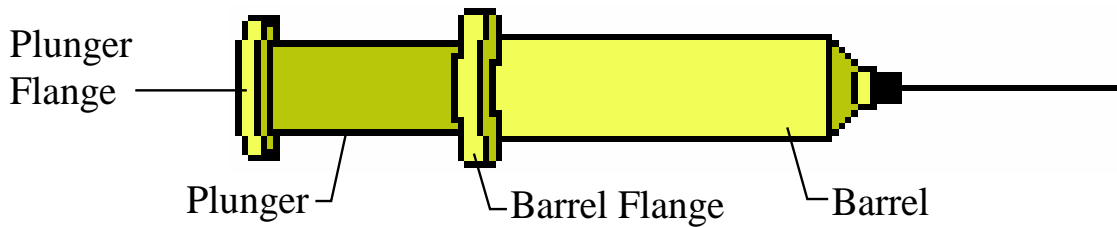

Terminology

Pumping Program:	The sequence of automated operations entered into the pump. This could be as simple as a single function to pump at a single infusion rate continuously.
Pumping Program Operating:	When the pump is started with the 'Start'/'Stop' key, or any other source, the pump begins performing the operations in the Pumping Program until the Pumping Program either stops automatically or the pump is stopped when the 'Start/Stop' key is pressed, or from any other source. While performing the operations defined in the Pumping Program, the Pumping Program is referred to as operating. While Operating, the motor can be pumping or stopped, according to the Pumping Program.
Pumping Program Stopped:	The motor is stopped and the pump is not operating the Pumping Program..
Pumping Program Paused:	The Pumping Program has been stopped, but can be resumed at the point where it was stopped.
Pumping Program Resumed:	Continuing a Pumping Program that was Paused before the completion of the Pumping Program. The Pumping Program continues at the point where the Pumping Program was stopped.
Executed:	The pump has performed a single operational Phase as defined in the Pumping Program.
Program Phase:	A single defined operation in the Pumping Program.
Phase Number:	A Program Phase's numerical sequence location in the Pumping Program.
Currently Selected Function:	Each Pumping Program Phase instructs the pump to perform a particular operation. Only one Program Phase is selected at any one time. This is the current Phase. Each Phase is set to one function. The set function of the current Phase is the currently selected function.
Pumping Rate Function:	Each Pumping Program function instructs the pump to perform a particular operation. If the Phase's operation instructs the NE-1000 to pump, then associated with that Phase is the Phases' pumping information. When 'Program Entry Mode' is exited, the 'Rate', 'Volume', and pumping direction keys refer to the currently selected Program Phase's function. The Program functions that are associated with pumping information are referred to as Pumping Rate functions.
Function Parameter:	Certain functions, which do not instruct the NE-1000 to pump, require additional data. This additional data, displayed with the function, is the function's parameter.
Start Trigger:	The Pumping Program may be started, or stopped, from multiple sources. These are the TTL I/O 'Operational Trigger' input, or from a command received through the RS-232 connection.

3. Setup

- ◆ Place the pump on a stable surface.
- ◆ Plug the connector end of the power supply into the power plug located on the PCB on the side of the pump. See section 9, Logic Interface: TTL Input and Output, for a diagram of the connectors on the pump. After power is applied to the pump, the buzzer will beep.
- ◆ Attach the pump's serial port to the computer's serial port using the CBL-PC-PUMP-7. Attach the RJ-11 (Telephone connector) to the pump's "To Computer" connector. Attach the DB-9 connector to the proper connector on the computer.
- ◆ Start the PUMPTERM emulator communications program.
- ◆ Next the Pumping Program can be entered. Before the Pumping Program can be operated, the pump needs the measurement of the inside diameter, in millimeters, of the syringe that will be loaded. The syringe diameter is entered using the "DIA" command.
- ◆ Finally, the syringe can be loaded and the pump started.

4. Loading Syringes

The syringe is loaded by securing the barrel and the pusher flange as follows:

- 1: Loosen the 2 **thumbscrews** on the **syringe retainer bracket**.
 - 2: Press in fully the white **drive-nut button** on the **pusher block**, releasing the block. Taking care not to drag the drive-nut on the drive-screw, slide the block away from the syringe holder, providing sufficient space for the loaded syringe. Then release the white button.
 - 3: Lift the **syringe holder** above the **syringe holder block**. Turn it 1/4 turn and then lower it onto the syringe holder block. The syringe holder should be out of the **'V' slot**.
 - 4: Load the syringe with the **barrel** over the syringe holder and the syringe **plunger** towards the middle of the pump. Place the barrel on the syringe holder, in the 'V' slot, with the **barrel flange** inserted between the syringe holder block and syringe retainer bracket.
 - 5: On the pusher block, turn the thumbscrew to make the slot large enough for the **plunger flange**. Press in fully the white drive-nut button on the pusher block, releasing the pusher block. Then slide the block towards the syringe plunger. Place the syringe **plunger flange** into the slot and against the **anti-siphon plate**. When the flange is positioned in the slot, release the white drive-nut button.
 - 6: Lift the syringe holder to slightly above the height of the syringe barrel and turn the syringe holder 1/4 turn back to its original position and then lower it onto the syringe barrel.
 - 7: Firmly push in the syringe retainer bracket against the syringe barrel flange and tighten the 2 thumbscrews on the syringe retainer bracket. On the pusher block, turn the thumbscrew to tighten the plate against the **plunger flange**.
- ⇒ To unload the syringe, reverse the instructions for syringe loading.

5. Operation



Before the pump can be operated, the pumping data must be setup. At minimum, the syringe inside diameter and a non-zero pumping rate needs to be set. The operation of the pump can then be started from the TTL I/O connector, or from RS-232 computer control.

All data that is set will be stored in the pump's non-volatile memory, meaning that the new value will not be lost the next time that power is applied to the pump. The only exception is when the pumping rate is changed while the Pumping Program is operating. In this case the new pumping rate will not be stored in non-volatile memory.

In general, numeric data are floating point data consisting of up to 4 digits plus 1 decimal point, and is referred to in the command descriptions as <float> data. For example 123.4 , 12.3 and 12.34 are acceptable formats for floating point data.

5.1 Syringe Inside Diameter

Set with command: DIA <float>

The syringe inside diameter can only be set while the Pumping Program is stopped.

Valid syringe diameters are from 0.1 mm to 50.0 mm. If the diameter is out of this range, the response will be '?OOR'. Changing the syringe diameter **will not zero any current settings**. Section 10.1, Syringe Diameters and Rate Limits, is a representative list, for reference, of syringe diameters for various syringe manufacturers and syringe sizes.

5.1.1 Default Volume Units

The units of the accumulated infusion and withdrawal volumes and the "Volume to be Dispensed" are set according to the diameter setting:

From 0.1 to 14.0 mm	Syringes smaller than 10 mL:	Volume units are 'µL'
From 14.01 to 50.0 mm	Syringes greater than or equal to 10 mL:	Volume units are 'mL'

5.2 Start/Stop Triggers

Start Command: "RUN"

Stop Command: "STP"

The Pumping Program can be started or stopped from any of the different sources. The 'RUN' command, or the TTL I/O Operational Trigger input. Each can control the Pumping Program's operation.

5.3 Operating the Pump

When a start trigger is given, the Pumping Program begins to operate, starting with Phase 1. If the current Program Phase specifies a pumping rate, the pump will begin pumping. The pumping direction will depend on the Phase setup. The volume dispensed can be queried with the 'DIS' command.

While pumping, the pump will pump continuously in the current Program Phase, unless a "Volume to be Dispensed" is set, or an Event trigger is set. If a "Volume to be Dispensed" is set, the Program Phase will be complete after the set volume has been infused or withdrawn, measured from the start of the Phase.

5.4 Pumping Rate

Command: "RAT [<float> [<units>]]"

Sets/queries the pumping rate and rate units.

5.4.1 Changing the Pumping Rate and Direction While Pumping

Command: "RAT <float>"

Except with some complex Pumping Programs, the pumping rate can be changed while the pump is operating. To change the pumping rate while pumping, use the 'RAT' command to send a new rate. **A new rate set while pumping will not be stored in non-volatile memory.** Rate units cannot be changed while pumping.

If the new rate is valid, it will take affect immediately.

The pumping direction can be changed while pumping if the "Volume to be Dispensed" is 0.0. The direction command "DIR" will immediately change the pumping direction and store the pumping direction in the current Program Phase. Also changing the pumping direction changes the accumulated "Volume Dispensed" according to the new pumping direction.

5.5 Pumping Direction

Command: "DIR [INF | WDR]"

Sets the direction of pumping to Infuse (INF) or Withdraw (WDR)

5.6 Dispense Volume Target and Continuous Pumping

Command: "VOL [<float>]"

To set a dispense volume, use the "VOL" command. The units of volume are set according to the syringe diameter to either μL or mL. The current Pumping Phase will continue to pump, infusing, or withdrawing, until the set volume has been pumped.

For continuous pumping, set the volume target to 0: Command "VOL 0".

5.7 Volume Dispensed

Volume is computed based upon the syringe inside diameter setting. The volume is accumulated separately for infusion and withdrawal. The volume dispensed for infusion and withdrawal can be queried with the "DIS" command.

The "Volume Dispensed" accumulations, for infusion and withdrawal, are reset to 0 when:

- A) The pump is powered on.
- B) The syringe diameter is changed.
- C) From the RS-232 clear "Volume Dispensed" command (CLD).
- D) The accumulated Volume Dispensed rolls over from 9999 to 0.

5.8 Resuming When Paused

If the Pumping Program is stopped before the completion of the Pumping Program, the response prompt will change to 'P', indicating that the Pumping Program is paused. While paused, starting the pump again will resume the Pumping Program where it was stopped. This means that the Pumping Program will continue at the point in the Phase where it was stopped and the 'Volume to be Dispensed' will still be referenced from when the Program Phase first started.

Pause is exited by sending a stop command "STP", or changing any setting. When the Pumping Program is started again, it will start from the beginning (Phase 1).

5.9 Pump Stalled

Model: NE-501 only

When the operation of the motor is impeded due to excessive force needed to drive the syringe, the pump will stop, pausing the Pumping Program, and a stall alarm will occur.

The buzzer will sound continuously if alarms are enabled. Also, if the RS-232 Safe Mode is enabled, an auto-alarm message will be sent to an attached computer.

Sending any command will stop the buzzer and clear the alarm. When the problem causing the pump motor to stall has been corrected, the Pumping Program can be resumed by any start trigger, TTL input, or RS-232.

6. Setup Configuration

The following configuration parameters can be set or queried:

The values for "n" are "0" for off, "1" for on

<u>Command</u>	<u>Description</u>
ADR nn	Set the pump network address
PF n	Power Failure mode, where 'n' is the current setting.
AL n	Alarm mode, where 'n' is the current setting.
TRG aa	Operational Trigger configuration, where 'aa' is the current configuration.
DIN n	Directional control input setup
ROM n	Pump motor operating TTL output configuration

6.1 RS-232 Pump Network Configuration

Command: ADR [<nn> | <RECP> | <DUAL>]

The pump can be configured to communicate either with a computer or another pump. Communications with a computer (Address Mode) is the default setting and will be indicated by setting an address from 0 to 99.

When in the default Address Mode, up to 100 pumps can be attached to a computer in a single pump network. The network address is defined by the 2 digits to the parameter <nn>. If only one pump is attached to the computer, set the network address to 0, ADR 0, which is the factory default.

Additionally, the baud rate can be set with this command. For details see the detailed RS-232 command section.

Special communications modes:

ADR RECP	Reciprocating Pumps. Sends Start/Stop, Pumping rate and reverse pumping direction to an attached secondary pump.
ADR DUAL	Reciprocating Pumps. Sends Start/Stop, Pumping rate and same pumping direction to an attached secondary pump.

Note: Communications with a computer requires the accessory cable: CBL-PC-PUMP-7.
Communications with a secondary pump requires the accessory cable: CBL-DUAL

In Reciprocating or Dual Pumps Modes, the secondary pump must be left in its default communications setting of Address Mode, Address 0, and 19,200 baud rate. See the documentation with CBL-DUAL cable for more detailed information.

6.2 Power Failure Mode

Command: "PF <n>" <n> Setting: '0' = Disabled, '1' = Enabled.

When enabled, if the Pumping Program was operating when power to the pump was disrupted, the Pumping Program will automatically start operating when power is reconnected to the pump.



CAUTION: The Pumping Program will start operating from the beginning of the Pumping Program (Phase 1), regardless of what part of the Pumping Program was operating when the power was disrupted.

When the NE-500/501 syringe pump is used as a component in an automated infusion/withdrawal dispensing system, a Pumping Program can be designed to automatically synchronize the pusher block at the start of the Pumping Program. This would be accomplished using attached sensors that send signals to the Pumping Program.

6.3 Audible Alarm Enable

Command: "AL <n>", <n> Setting: '0' = Disabled, '1' = Enabled.

When alarms are enabled, the buzzer will be sounded as follows:

Condition	Buzzer Action
Pumping Program ended	Continuous beeping
Pumping Program paused for start trigger	Continuous beeping
Alarm condition, such as pump motor stalled	Steady alarm

Any command sent to the pump will stop the alarm.

6.4 TTL I/O Operational Trigger Configuration

Command: "TRG <aa>", <aa> as below in Settings.

Configures how the TTL I/O 'Operational Trigger' (pin 2) will control the Pumping Program's operation. (See sec. 9.1, *TTL I/O Operational Controls*).

Setting	Name	Function
FT	Foot Switch	Falling edge starts or stops the Pumping Program
LE	Level Control	Falling edge stops the Pumping Program Rising edge starts the Pumping Program
ST	Start Only	Falling edge starts the Pumping Program
SP	Stop Only	Falling edge stops the Pumping Program

6.5 TTL I/O Directional Control Input Configuration

Command: "DIN <n>"

Configures how the TTL input 'Pumping Direction' (pin 3) will control the pumping direction. (See sec. 9.1, *TTL I/O Operational Controls*).

Setting	Mode	Function
0	Reciprocating Pumps	Falling edge: Infuse; Rising edge: Withdraw - Used for 2 pumps operating in opposite directions

1	Dual Pump	Falling edge: Withdraw; Rising edge: Infuse - Used with 2 pumps operating in the same direction
---	-----------	--

6.6 Pump Motor Operating TTL Output Configuration

Command: "ROM <n>"

Configures the functionality of the 'Pump Motor Operating' TTL output pin (TTL pin 7).

Setting <n>	Mode
0	Sets the output to logic high only when the motor is operating (pumping). Sets the output to logic low when the motor is not operating or when the Pumping Program is executing a pause timer or is stopped
1	Sets the output to logic high when the motor is operating (pumping) or when the Pumping Program is executing a pause timer. Sets the output to logic low when the Pumping Program is stopped

7. Pumping Program

A Pumping Program is simply a pre-defined sequence of actions, or functions, which guarantees consistent and precise operation of the pump, automatically and with or without any user intervention. A Pumping Program can be as simple as continuous pumping at a fixed infusion rate. Or a Pumping Programs could consist of a pumping rate and direction of pumping for a specified volume, then switch to another pumping rate. Also a Program can interact with external devices through the TTL I/O connector, make decisions, or stop pumping for a period of time.

Programs are broken into individual operations called Phases. Each Phase consists of a function that can be a control function or pumping function. A pumping function, such as 'RATE', consists of a pumping rate, optional "Volume to be Dispensed", and the pumping direction.

Complex dispensing systems can be designed, involving multiple liquids, each dispensed from a different pump, plus other equipment and sensors. Pumping Programs can be designed for each pump which enable multiple pumps to synchronize with each other, and the other equipment and sensors, using a cable connected to the TTL I/O connectors of each pump.

When the Pumping Program is started, either from the keypad, TTL I/O connector, or from RS-232, the Pumping Program will begin with Phase 1 of the Program. After the completion of each Phase, the pump will immediately start the next consecutive Phase. This linear sequence of Phases can be altered by certain functions that direct the Pumping Program to continue operation with a different Phase number. Some functions can change the order of operation conditionally based on external events.

7.1 How to Enter Pumping Programs

Start by organizing your pumping requirements into specific actions and conditions that can then be programmed into Phases. For more advance programming methods, common groups of Phases can be grouped together and repeated multiple times using looping and jump functions.

The current values of the pumping rate, optional "Volume to be Dispensed", and pumping direction, all refer to the currently selected Phase. Use the command "PHN" to set the current phase.

To change the "Program Function" of the currently selected program phase, use the "FUN" command. When finished sending the data for the current Phase, use the "PHN" command to select the next program phase to be set. Now all pumping data will refer to next currently selected Phase. Data for the current Phase can now be entered.

Continue selecting Phase numbers and entering the infusion or control setup for each Phase of the Pumping Program. The entire Pumping Program will be stored in non-volatile memory.

Use the 'STOP' function (FUN STP) to stop the pump and end the Pumping Program. If the Pumping Program does not operate the pump continuously, the last Phase of the Pumping Program must be a 'STOP' function (unless the last Phase number is the maximum Phase number).

When the Pumping Program is started, with the TTL I/O input, or RS-232 command, the Pumping Program will begin operating from Phase 1.

Very complex dispensing Programs can be created with the Program functions available. Section 7.3 contains a detailed description of all the functions.

7.2 Clearing The Pumping Program

To clear out the pumping program memory and reset communication parameters, send the command: `"*RESET"`

7.3 Program Function Descriptions

7.3.1 Rate Function

Command: `"FUN RAT"`

This is the most basic function to simply command the pump to pump to dispense and a specific rate.

Defines a pumping function with a fixed pumping rate. This function defines a pumping setup consisting of the pumping rate, optional "Volume to be Dispensed", and pumping direction. Use the 'RAT', 'VOL', and 'DIR' commands to set or review the Rate Function's setup. For continuous pumping, set the "Volume to be Dispensed" to 0.0.

7.3.2 Increment Rate Function

Command: `"FUN INC"`

The increment and decrement functions operate the same as the 'RATE' function, except that the specified rate is added ('INC') or subtracted ('DEC') from the current pumping rate. The current pumping rate when the function is executed is the base pumping rate for the function. If no base pumping rate exists, such as when executing a pause function or when the Pumping Program is first started, a Program error will occur and the Program will stop.

The pumping rate units will be the same as the base pumping rate, and therefore cannot be set, or queried, with the pumping rate increment or decrement value. As with the 'RATE' function, a "Volume to be Dispensed" and pumping direction can be specified for the increment and decrement functions.

When used within a Program loop, the pumping rate can be incremented or decremented in small step intervals.

7.3.3 Decrement Rate Function

Command: `"FUN DEC"`

The decrement function subtracts the specified rate from the current pumping rate. For a full description, see section 7.3.2, Increment Rate Function

7.3.4 Stop Pumping Operation and End The Program

Command: `"FUN STP"`

Stops the pumping operation and stops the Pumping Program. The Pumping Program will begin at Phase 1 when started again. An implicit 'Stop' function is executed when the Program exceeds the maximum Phase number during operation.

If alarms are enabled, the buzzer will beep continuously when the Pumping Program stops.

7.3.5 Jump to Phase Function

Command: "FUN JMP nn"

The 'Jump' function alters the consecutive operation of Program Phases. When executed, the Pumping Program will continue operation with Phase 'nn'.

7.3.6 Define Starting Phase of Loop Function

Command: "FUN LPS"

Defines the start of a Program loop. For a full description of Program looping, see sec 7.3.8, Define Loop End and Loop Repetitions Function

7.3.7 Define Continuous Loop End Function

Command: "FUN LPE"

Loops to the most recently executed, unpaired, 'loop start' Phase, or Phase 1 if none. This function allows a section of the Program to be repeated continuously. For a full description of Program looping, see sec.7.3.8 Define Loop End and Loop Repetitions Function.

7.3.8 Define Loop End and Loop Repetitions Function

Command: "FUN LOP nn"

Repeats execution of the defined loop 'nn' times.

Loop starts and loop ends are uniquely **paired** during looping. When an unpaired 'loop end' function is executed, it is paired with the most recent unpaired 'loop start' function executed ('FUN LPS'). If no unpaired 'loop start' function exists, Phase 1 is used as an implied unpaired 'loop start'. This pairing defines the loop and the range of Phase numbers between the paired loop functions defines the **scope** of the loop.

When a 'loop end' function is executed, Program operation continues with the 'loop start' function paired with the loop end function. There are 2 'loop end' functions: Loop continuous ('FUN LPE') and Loop for a preset number of iterations ('FUN LOP nn'), indicated by 'nn'. Each time a paired 'loop end' function is executed, an iteration of the loop is complete. With the 'FUN LOP nn' function, after 'nn' number of loop iterations, the defined loop is complete and Program execution continues with the next Program Phase after the 'loop end' function. The loop is then no longer defined or paired.

While executing Phases within the scope of a defined loop, another 'loop start' and 'loop end' can be paired and become a defined loop within the scope of the first loop, which is referred to as the outer loop. The new loop being referred to as the inner loop. The pairing of a loop within a paired loop is referred to as nesting of loops, with each loop being one nested layer for the duration of the loops pairing. Loops can be nested for a total of 3 layers deep. Loops can only be nested within the scope of an outer loop.

7.3.9 Pause Pumping Function

Command: "FUN PAS <nn | n.n>"

If 'nn' is non-zero, the Pumping Program will pause pumping (stops pumping) for 'nn' seconds. After the pause interval, the next Program Phase will be executed. 'nn' can range from 00 to 99 or 0.1 to 9.9 seconds.

For pauses longer than the '99' second maximum pause for this function, put the pause function within a Program loop. A Program section with the following functions in consecutive Phases:

[FUN LPS] [FUN LPS] [FUN PAS 60] [FUN LOP 60] [FUN LOP 24],

will pause the Pumping Program for 24 hours.

If 'nn' is '00' then the Pumping Program pauses and waits for a start trigger to resume the Program

After the start trigger, the Program will resume with the next Phase. The start trigger can be from any source, the TTL I/O Operational Trigger, or from RS-232.

If alarms are enabled, the buzzer will beep continuously while waiting for the start trigger.

7.3.10 Jump to Phase If External Trigger Function

Command: "FUN IF nn"

The 'IF' function conditionally alters the Pumping Program's execution based on an external signal.

When executed, if the TTL I/O Program Input pin (pin 6) is low level, then the Pumping Program continues operation with Phase number 'nn'. Otherwise, the Pumping Program continues operation with the next Phase.

7.3.11 Setup Event Trigger Jump Phase Function

Command: "FUN EVN nn"

The 'Event' function sets a background event trap that is triggered by an external signal.

This one time background trap, or interrupt, stays set during the Pumping Program's entire execution until it is triggered or reset. This function has no other affect on the operation of the pump until it is triggered.

The event is triggered when either:

- 1) A falling edge (high to low TTL transition) occurs on the TTL 'Event Trigger' input (pin 4) or
- 2) A low level on the 'Event Trigger' input pin at the time when the function is executed.

When triggered, the current operation of the pump and the Pumping Program is interrupted, and the Pumping Program immediately continues operation (jumps to) with Phase number 'nn'.

After being triggered, the event trigger is reset. If an event trigger function is executed while another event trap is still set, the new event trigger will replace the previous event trap.

7.3.12 'ES:nn': Setup Event Square Wave Trigger Jump Phase

Command: "FUN EVS nn"

The 'Event Square Wave' function operates the same as the 'EVN' 'Event' function, with the exception of the triggering conditions.

This function will trigger on either the rising or the falling edge of the TTL 'Event Trigger' input (pin 4).

Therefore, a square wave function on the inupt pin can be used to toggle the pump between 2 sections of a Pumping Program. An example of this would be a Pumping Program that switched between a slow and fast pumping rate, controlled by a square wave input.

7.3.13 Event Reset Function

Command: "FUN EVR"

'Event Reset' cancels a previously set event trap.

7.3.14 Set TTL Output Pin Function

Command: "FUN OUT n"

Set 'Program Output' TTL I/O output (pin 5) to level 'n'.

If 'n' = 0, the output pin will be set low. If 'n' = 1, the output pin will be set high.

7.3.15 Beep Function

Command: "FUN BEP"

Sounds a short beep.

7.4 Pumping Program Examples

7.4.1 Example 1: 2 Step Rate

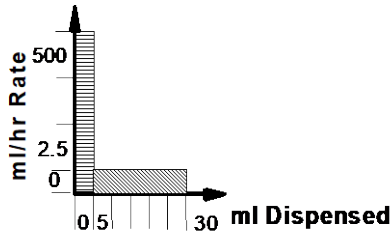

Infuse 5.0 ml at 500 ml/hr, then infuse 25.0 ml at 2.5 ml/hr. Then stop the pump.

Phase	Function	Rate	Volume	Direction
1	RAT	500 ml/hr	5.0 ml	Infuse

Phase	Function	Rate	Volume	Direction
2	RAT	2.5 ml/hr	25.0 ml	Infuse

Phase	Function
3	STP

To send this program to the pump, send the following sequence of commands:

```
PHN 1
FUN RAT
RAT 500 MH
VOL 5.0
DIR INF
PHN 2
FUN RAT
RAT 2.5 MH
VOL 25.0
DIR INF
PHN 3
FUN STP
```

7.4.2 Example 2: Repeated Dispenses with Suck Back

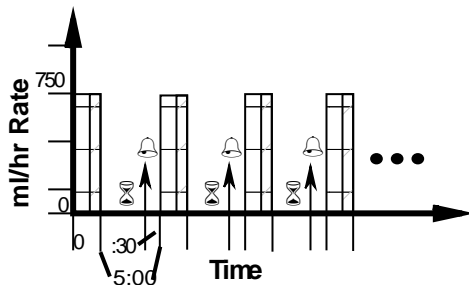

Dispense 2.0 ml with a 5 minute pause between dispenses. In addition, after each dispense, a volume of 0.25 ml is sucked back to prevent dripping. Also, 30 seconds before the end of the pause interval, a beep is sounded to alert the operator to prepare for the next dispense.

Starting with the second dispense, 0.25 is added to the volume dispensed to compensate for the sucked back volume of the previous dispense. By changing the last Phase to a [FUN LOP nn] function, the total number of dispenses can be set.

When entering a function with associated data, such as with the ‘Pause’ in Phase 5, or the ‘Loop’ in Phase 6, the function is entered in 2 steps. First select the function and store it. Then enter the associated data.

Phase	Function	Rate	Volume	Direction
1	RAT	750 ml/hr	2.0 ml	Infuse

Phase	Function	Rate	Volume	Direction
2	RAT	750 ml/hr	0.25 ml	Withdraw

Phase	Function
3	LPS

Phase	Function
4	LPS

Phase	Function
5	PAS 90

Phase	Function
6	LOP 03

Phase	Function
7	BEP

Phase	Function
8	PS:30

Phase	Function	Rate	Volume	Direction
9	RAT	750 ml/hr	2.25 ml	Infuse

Phase	Function	Rate	Volume	Direction
10	RAT	750 ml/hr	0.25 ml	Withdraw

Phase	Function
11	LPE

7.4.3 Example 3: Ramping the Flow Rate

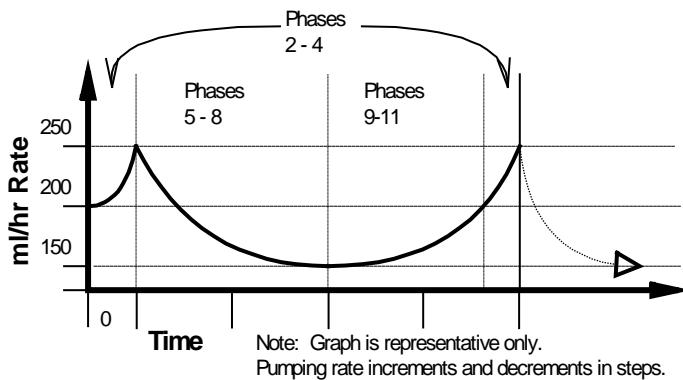

Continuously ramp up and down the pumping rate. Starting at 200 ml/hr, the pumping rate will increment to 250 ml/hr in 1.0 ml/hr steps after every 0.1 ml has been dispensed. Then the pumping rate will decrement to 150 ml/hr in 1.0 ml/hr steps after every 0.1 ml has been dispensed. Finally, the pumping rate is incremented back to 200 ml/hr in 1.0 ml/hr steps after every 0.1 ml has been dispensed, then the process is repeated.

Phase	Function	Rate	Volume	Direction
1	RAT	200 ml/hr	0.1 ml	Infuse

Phase	Function
2	LPS

Phase	Function	Rate	Volume	Direction
-------	----------	------	--------	-----------

3	INC	1.0	0.1 ml	Infuse
---	-----	-----	--------	--------

Phase	Function
4	LOP 50

Phase	Function
5	LPS

Phase	Function	Rate	Volume	Direction
6	DEC	1.0	0.1 ml	Infuse

Phase	Function
7	LOP 99

Phase	Function	Rate	Volume	Direction
8	DEC	1.0	0.1 ml	Infuse

Phase	Function
9	LPS

Phase	Function	Rate	Volume	Direction
10	INC	1.0	0.1 ml	Infuse

Phase	Function
11	LOP 50

Phase	Function
12	JMP 02

7.4.4 Example 4: Complex Dispenses with External Synchronization

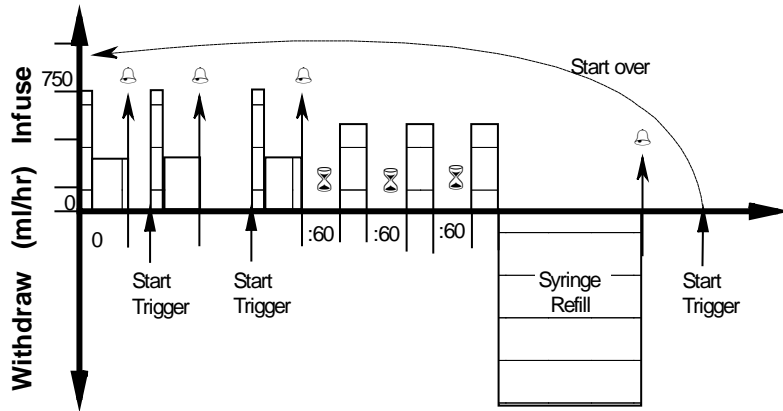

A more complex dispensing example, this Program contains different pumping requirements, including dispenses with multiple pumping rates. The first set of 3 dispenses drops down to a lower pumping rate during the dispense. When each dispense is completed, the buzzer beeps to alert the operator, then the pump waits for a start trigger before starting the next dispense.

The next set of 3 dispenses have a fixed time interval of 60 seconds between dispenses. After the last set of dispenses, the syringe is refilled by the amount infused, 17.25 ml. Then the buzzer beeps, to alert the operator to the start of the first set of dispenses. The process is then repeated.

Phase	Function	Rate	Volume	Direction
1	RAT	750.0 ml/hr	0.5 ml	Infuse

Phase	Function	Rate	Volume	Direction
2	RAT	300.0 ml/hr	1.5 ml	Infuse

Phase	Function
3	BEP

Phase	Function
4	PAS 00

Phase	Function
5	LOP 02

Phase	Function	Rate	Volume	Direction
6	RAT	750.0 ml/hr	0.5 ml	Infuse

Phase	Function	Rate	Volume	Direction
7	RAT	300.0 ml/hr	1.5 ml	Infuse

Phase	Function
8	BEP

Phase	Function
9	LPS

Phase	Function
10	PAS 60

Phase	Function	Rate	Volume	Direction
11	RAT	500.0 ml/hr	3.75 ml	Infuse

Phase	Function
12	LOP 03

Phase	Function	Rate	Volume	Direction
13	RAT	900.0 ml/hr	17.25 ml	Withdraw

Phase	Function
14	BEP

Phase	Function
15	PAS 00

Phase	Function
16	LPE

7.4.5 Example 5: Control from a High-Low Pressure Sensor

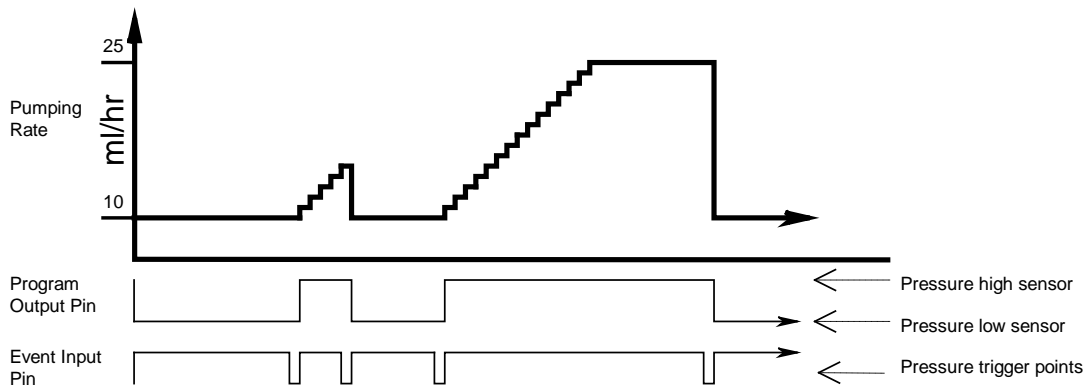

This example demonstrates a Pumping Program whose control depends on an external sensor. Assuming a pressure sensor that is configured to detect a high pressure point and a low pressure point, the Pumping Program individually selects whether it will react to the high or low pressure point.

The “Program Output” pin on the TTL I/O connector (pin 5) is used to select the high or low pressure

point. When low, the low pressure point is selected (PHASE 01), and when high, the high pressure point is selected (PHASE 05). The Program begins by infusing continuously at 10.0 ml/hr (PHASE 02), while a background trap is set for the low pressure point (PHASE 03). To create a delay when the pressure sensor is switched from high pressure to low pressure when the “Program Output” pin is set, a small volume is pumped (PHASE 02, 06) before the background traps are set.

When the low pressure trap is triggered, the pump sets the high pressure trap (PHASE 07) and begins to increment the flow rate. The flow rate is incremented in 1.0 ml/hr steps with every 0.25 ml dispensed (PHASE 08-10). If the high pressure trap hasn't as yet been triggered, the flow rate will max out at 25.0 ml/hr while waiting for the high pressure trap (PHASE 11). When the high pressure point is reached, the pump immediately will drop down to 10.0 ml/hr (PHASE 02), and once again wait for the low pressure point.

Phase	Function
1	OUT 0

Phase	Function	Rate	Volume	Direction
2	RAT	10.0 ml/hr	0.005	Infuse

Phase	Function
3	EVN 05

Phase	Function	Rate	Volume	Direction
4	RAT	10.0 ml/hr	0.0 ml (off)	Infuse

Phase	Function
5	OUT 1

Phase	Function	Rate	Volume	Direction
6	RAT	10.0 ml/hr	0.005	Infuse

Phase	Function
7	EVN 01

Phase	Function
8	LPS

Phase	Function	Rate	Volume	Direction
9	INC	1.0	0.25 ml	Infuse

Phase	Function
10	LOP 14

Phase	Function	Rate	Volume	Direction
11	RAT	25.0 ml/hr	0.0 ml (off)	Infuse

7.4.6 Example 6: Automated Dispensing with Synchronization

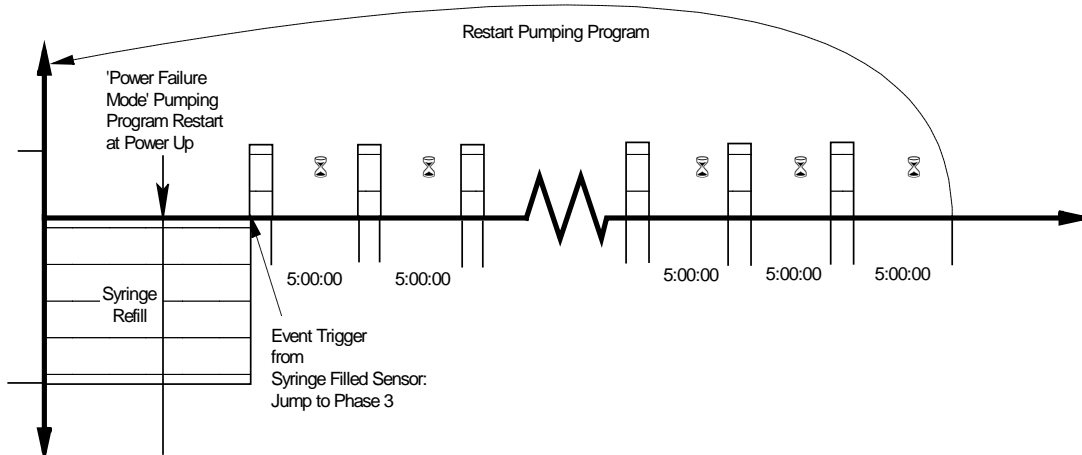

The following is an automated dispensing Program for a NE-500/501 syringe pump equipped with a ‘Syringe Filled Sensor’ attached to the TTL I/O connector, and a valve system to refill the syringe from a reservoir. It is also assumed that the ‘Power Failure’ mode is enabled.

After a power fail restart, the pusher block is in an unknown position, making it impossible for an automated dispensing system to regain synchronization. With a Syringe Filled Sensor, the following Pumping Program will automatically synchronize the dispensing system, then continue with the normal dispense.

The first 2 Phases set an event trap for a Syringe Filled Sensor and refills the syringe until the sensor is triggered. When the sensor triggers the event, the pump’s pusher block will be synchronized with the Pumping Program. It is assumed that the sensor is positioned to refill the syringe with 60 ml. A withdraw volume of 61 ml is set as a safety feature.

After the syringe is refilled, one 5 ml dispense is made every 5 hours. After 12 dispenses, the syringe is refilled using the sensor again.

Phase	Function
1	EVN 03

Phase	Function	Rate	Volume	Direction
2	RAT	1000.0 ml/hr	61 ml	Withdraw

Phase	Function
3	LPS

Phase	Function	Rate	Volume	Direction
4	RAT	200.0 ml/hr	5.0 ml	Infuse

Phase	Function
5	LPS

Phase	Function
6	LPS

Phase	Function
7	PAS 60

Phase	Function
8	LOP 60

Phase	Function
9	LOP 05

Phase	Function
10	LOP 12

Phase	Function
11	JMP 01

7.4.7 Example 7: Dispensing with Complex Synchronization

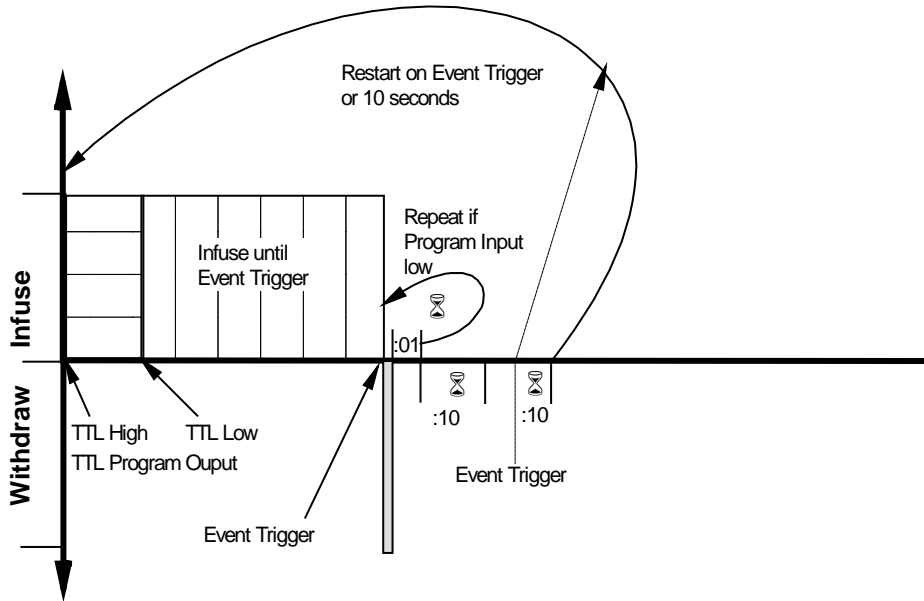

This example demonstrates a complex interaction with external equipment, such as synchronizing with another syringe pump. The Program includes a variety of interactions with external equipment, which demonstrates the various control possibilities of the NE-500/501.

The Pumping Program begins by canceling any previous event traps (PHASE 01) and raising the ‘Program Output’ TTL line (PHASE 02). After 5.0 ml has been dispensed at 800 ml/hr (PHASE 03), the ‘Program Output’ TTL line is lowered (PHASE 04), sending a synchronization signal to another device.

The pump then continues to pump at 800 ml/hr (PHASE 06) until a synchronization signal is received at the ‘Event Trigger’ TTL input, causing the Program to jump to Phase 7 (PHASE 05).

The pump then withdraws 0.25 ml (PHASE 07), pauses for 1 second (PHASE 08), then repeats this process if the Program Input TTL line is low (PHASE 09), otherwise it continues with the next Phase.

Next, the pump pauses for 10 seconds (PHASE 10). Then it pauses again for the lesser of another 10 seconds (PHASE 12) or until an Event Trigger occurs (PHASE 11). The Program then restarts (PHASE 13).

Phase	Function
1	EVR

Phase	Function
2	OUT 1

Phase	Function	Rate	Volume	Direction
3	RAT	800.0 ml/hr	5.0 ml	Infuse

Phase	Function
4	OUT 0

Phase	Function
5	EVN 07

Phase	Function	Rate	Volume	Direction
6	RAT	800.0 ml/hr	0.0 ml	Infuse

Phase	Function	Rate	Volume	Direction
7	RAT	1000.0 ml/hr	0.25 ml	Withdraw

Phase	Function
8	PAS 01

Phase	Function
9	IF 07

Phase	Function
10	PAS 10

Phase	Function
11	EVN 01

Phase	Function
12	PAS 10

Phase	Function
13	JMP 01

8. RS-232 Communications

The NE-500/NE-501 Syringe Pump can communicate with any computer, software package, or device with an RS-232 communications port.



8.1 Connection and Networking

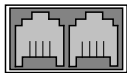

On the side of the pump are 2 square RJ-11 (“phone jack” style) sockets. Connect the RS-232 cable into the socket labeled “Computer”. Connect the other end to the serial port on the computer, or other control device. Turn power off to the pump and the computer before connecting cables.

If the pump is part of a pump network, connect a pump network cable between the socket labeled “Pump Network”, on the first pump, and the socket labeled “Computer” on the next pump in the network. Repeat for each pump in the network, connecting the “Pump Network” socket of one pump to the “Computer” socket on the next pump in the network. Up to 100 NE-500/NE-501 pumps can be network together, along with other pumps from the NE-1000 family of pumps, to one communications port on a computer. See section 9, Logic Interface: TTL Input and Output, for a diagram of the rear of the pump. When communicating with a pump in a multi-pump network, each preceding pump in the network must be powered on.

Each pump in the network needs a unique network address to identify the pump to the computer. Network addresses are from 00 to 99. If the network consists of only 1 pump, set the pump’s address to 0, the factory default address. Also, each pump needs to be set to the same baud rate as the computer. The default baud rate is 19,200.

8.2 RS-232 Pump Network Configuration

If only one pump is being used, leave the address at the default of 0.

Up to 100 pumps from the NE-1000 family of pumps can be attached to a computer in a single pump network. The network address is set using the command `*ADR nn`, where “nn” is the pump’s network address from 0 to 99. If only one pump is in the network, leave the address at the default address of 0. This will simplify communications because the address can be left off the commands sent to the pump.

To set the network address, individually attach each pump to the computer. Disconnect the network cable from the “Network” connector on the pump. Using the `*ADR nn` command, send a unique address to each pump from 0 to 99. This operation only has to be performed once. The set address will be stored in the pump’s non-volatile memory and will take affect immediately. Once the set address command is sent, the pump will only respond to commands sent to the set address.

To query a pump’s current network address, send the command `*ADR` without any parameters. The pump will respond with its current pump address in the response packet’s data field.

8.3 RS-232 Protocol

When the pump is used in a multi-pump network configuration, precede each command with a pump address. Pumps will ignore all commands that do not have their defined network address. If the network address is not specified in the command, the address will default to 0.

After a command is sent to the pump, the pump will not accept any further communications until the current command has been processed. Completion of the command processing is indicated when the first byte of the response packet is transmitted

Communications to and from the pump use the following data frame:

Supported RS-232 Data Frames

Baud rate: 19200
 Frame: 10 bit data frame (8N1):
 Start bit: 1
 Data bits: 8
 Stop bits: 1
 Parity: None

Every command received by a pump in the network is acknowledged by the pump with a response packet that includes a status character indicating the current operational state of the pump.

Two packet protocols are supported, Basic and Safe. The enabled communications protocol is stored in non-volatile memory, and therefore will be in affect at power up. Safe Mode provides a safer communications protocol than Basic Mode. Safe Mode detects corrupted data and loss of communication, as well as automatically transmitting status packets when an alarm occurs.

Considering that the 19200 baud rate communicates at 52 μ s per bit, a small glitch on the RS-232 cable, flipping a single bit, can convert a transmitted infusion rate of 100 ml/hr into 900 ml/hr, the need for the Safe Mode in a production environment is evident. However, Basic Mode is excellent for simplifying early development of a control program.

While in the Basic Mode, the pump will accept either communications protocol, Basic or Safe. Though the response packet will be in the current communications mode. This allows a computer's communication's driver to be designed with just one mode. A Safe Mode communications driver can send a 'SAF' command to the pump in the Safe Mode protocol while the pump is in Basic Mode. The response to the 'SAF' command, enabling Safe Mode, will then be in the Safe Mode protocol.

8.3.1 RS-232 General Syntax Legend

The following syntax expansion legend is common to all syntax expansions:
 Except where indicated, all command and response characters are ASCII data.

<float> => <f> [<float>]	Floating point number. Maximum of 4 digits plus 1 decimal point. Maximum of 3 digits to the right of the decimal point.
<volume units> => UL ML	μ l (microliters) ml (milliliters)
<TTL level> => 1 0	TTL high level TTL low level
<on-off> => 1 0	On, enabled Off, disabled
<phase data> => <n> [<n>]	Program Phase number. Valid values: 1 to 41
<count data> => <n> [<n>]	Valid values: 1 to 99
<number data> => <n> [<n>]	Valid values: 0 to 99
<text> => "any printable character" [<text>]	
<f> => { <n> . }	Floating point digits
<n> => { 0 1 2 3 4 5 6 7 8 9 }	Digits
<byte> => "one byte of any data"	
()	One byte of data expressed as (0xhh), where 'hh' is the data in hexadecimal.
=>	Is defined by. Syntax expands to next level of expansion.

< >	Non-terminal syntax expansion
[]	Optional syntax
{ }	Required syntax
	Or. Choose one of the syntax options.
λ	None. Syntax expands to nothing (lambda production).
" "	Description of syntax expansion

8.3.2 RS-232 Protocol: Basic Mode

Command syntax (to pump):

<basic command protocol> => <command data> <CR>

Response syntax (from pump):

<basic response protocol> => <STX> <response data> <ETX>

In the “Basic” communications mode, a master-slave protocol is used, whereby the pump will only transmit in response to a received command.

When the pump receives the <basic command protocol>, <command data> will automatically be stripped of all space and control characters, and all text will be converted to upper case. This simplifies communications with the pump when commands are being manually typed in from a generic terminal emulator.

To return the pump to Basic mode when in the Safe mode, send the following packet to the pump:

(0x2) (0x8) SAF0 (0x55) (0x43) (0x3)

8.3.3 RS-232 Protocol: Safe Mode

Command syntax (to pump):

<safe command protocol> => <STX> <length> <command data> <CRC 16> <ETX>

Response syntax (from pump):

<safe response protocol> => <STX> <length> <response data> <CRC 16> <ETX>

Safe mode uses a more structured protocol, including detection of corrupted communications, communications time outs, and auto-alarm responses. Safe mode is enabled using the ‘SAF’ command whose parameter setting is stored in the non-volatile memory.

Safe mode uses a modified master-slave protocol, whereby the pump transmits in response to a received command. But, the pump also automatically transmits a status packet when an alarm condition occurs.

Corrupted communications is detected using the 16 bit CCITT CRC algorithm computed over <transmitted data>. Packets transmitted and received include the CRC within the packets.

The parameter sent with the “SAF” command is the communications time out. This time out, in seconds, is the time between the reception by the pump of consecutive valid communications packets. Each time a valid communications packet is received, the time out is reset. If the time out elapses, a pump alarm will occur, stopping the pump and the Pumping Program. The buzzer will sound, if alarms are enabled, alerting the user. The communications time out timer will not restart until the next reception of a valid packet.

In addition, there is a 0.5 second packet inter-byte time out. While receiving a communications packet, and before its complete reception, if a delay of 0.5 seconds occurs between bytes, the incomplete packet will be discarded.

With the Auto-Alarm feature, whenever a pump alarm occurs, such as a pump stall, a response packet with the alarm status information will automatically be transmitted.

Until the Safe Mode is disabled, each time power is applied to the pump, the pump defaults to the Safe mode of communications, but the communications time out timer will not be enabled until the first reception of a valid packet.

Although the communications time out timer is not enabled, the Auto-Alarm feature will be enabled.

Therefore, the pump will be in an Auto-Alarm only communications mode.

When power is applied to the pump, or if the system should reset, a system reset alarm occurs. The Auto-Alarm feature, therefore, alerts the host computer that a pump reset has occurred.

8.3.4 RS-232 Protocol: Basic and Safe Mode Common Syntax

<transmitted data> => { <command data> <response data> }	
<command data> => [<address>] [<command>]	To pump
<response data> => <address> <status> [<data> <command error>]	From pump
<status> => { <prompt> <alarm> }	Operational state of pump
<prompt> =>	
I	Infusing
W	Withdrawing
S	Pumping Program Stopped
P	Pumping Program Paused
T	Pause Phase
U	Operational trigger wait (user wait)
<alarm> => A ? <alarm type>	Alarm
<alarm type> =>	
R	Pump was reset (power was interrupted)
S	Pump motor stalled
T	Safe mode communications time out
E	Pumping Program error
O	Pumping Program Phase is out of range
<address> => <n> [<n>]	Pump network address, 0 to 99
<data> => <text>	Response to command
<CR> => (0x0D)	Carriage return
<STX> => (0x02)	
<ETX> => (0x03)	
<CRC 16> => <byte> <byte>	16 bit CCITT CRC of <transmitted data> (high byte, low byte)
<length> => <byte>	Number of bytes remaining in packet, including this byte

8.3.5 Network Command Burst

The Network Command Burst feature is only applicable when communicating to a network of pumps.

This special feature allows commands to be sent to a network of pumps simultaneously. For example, changing the pumping rates simultaneously on a network of pumps.

Note: Since this special feature violates the general communications protocol of one command-one response, all of the pumps will be responding simultaneously, and therefore the communications response to a Network Command Burst will be gibberish and should be ignored.

Command Format

Command Burst => <n> <command> *

Network Command Burst => < Command Burst > [Network Command Burst]

Where <n> indicates the address of the pump that is to execute <command>. Maximum address is 9.

n => {0 ... 9}

Example: Change the pumping rates of the 3 pumps on a pump network as follows:

Pump 0: 100 ml/hr

Pump 1: 250 ml/hr

Pump 2: 375 ml/hr

Assumes that the current pumping rate units of all 3 pumps are currently ml/hr.

Send the following command, followed by a carriage return <CR>, (spaces are optional):

```
0 rat 100 * 1 rat 250 * 2 rat 375 *
```

8.4 Command Errors and Alarms

If a command received by the pump is not recognized or the data is invalid, an error message will be in the <data> field of the response packet following the <prompt> field. The following are the error responses:

```
<command error> => ? <error>
```

```
<error> =>
```

λ	Command is not recognized ('?' only)
NA	Command is not currently applicable
OOR	Command data is out of range
COM	Invalid communications packet received
IGN	Command ignored due to a simultaneous new Phase start

When an alarm occurs, the alarm must be acknowledged before any data is changed or the pump is started. Alarms are acknowledged by the user clearing the alarm message on the keypad, or the alarm status being sent in response to any valid RS-232 command. An alarm message sent automatically in the Safe Mode will not clear the alarm condition. This is to verify that the alarm message was sent to a receptive host, such as after a power failure when both the computer and the pump were reset. In this case, the pump will most likely send its reset alarm message before the computer has finished booting.

8.5 RS-232 Command Set

All data changed from RS-232 is stored in the non-volatile memory, except for changes to the pumping rate while pumping. All "Program Phase Data" refers to the currently selected Program Phase. Use the Phase select command ('PHN') to query or select the current Phase. A Phase consists of the pumping rate, 'Volume to be Dispensed', and the pumping direction.

A packet without a command is interpreted as a status query. The addressed pump responds with a status only response packet.

Except where noted, a command without any parameters is a query command. The response packet data will include the requested data. In general, the query response data will be in the same format as the parameters for setting the command. For example, the query diameter command 'DIA' will respond with '<float>' as the response '<data>'.

Otherwise, the command is a set command. If the data was set, a status only response packet will be sent. If the data was not set, the response packet will include an error (<command error>) message indicating why the data was not set.

All commands are upper case, but in Basic Mode, will be accepted as lower case, plus spaces and control characters will be ignored. This facilitates manually entering commands using a terminal emulator.

```
<command> =>
```

DIAMETER

```
DIA [ <float> ]
```

Set/query inside diameter of syringe. Set is only valid when the Pumping Program is not operating. Setting the syringe diameter also sets the units for "Volume to be Dispensed" and "Volume Dispensed".

8.5.1 Program Function Commands

The following commands are relevant to the currently select Program Phase. Note: During a Pumping Program's operation, the currently selected Phase can change automatically.

PHASE NUMBER

PHN [<phase data>]

Set/query currently selected Program Phase:

Set:

Currently selected Phase is set to <phase data>. Previous Phase is stored in non-volatile memory and the requested Phase is recalled from the non-volatile memory. Set is only valid if the Pumping Program is not operating.

Query response:

<phase data>

Currently selected Phase.

PUMPING PROGRAM FUNCTION

FUN [<phase function>]

Set/query the Pumping Program Phase's function.

This command is relevant to the currently selected Phase. Set is only valid if the Pumping Program is not operating

For a more detailed description of Program commands, see sec. 7.3, Program Function Descriptions.

<phase function> =>

Rate Data Functions

When a Phase's function is set to a "Rate Data Function", use the 'RAT', 'VOL', and 'DIR' commands to setup the pumping parameters.

RAT	Pumping rate. 'RATE'
INC	Increment rate. 'INCR'
DEC	Decrement rate. 'DECR'

Non-Rate Data Functions

STP	Stop pump. 'STOP'
JMP <phase data>	Jump to Program Phase.
LOP <count data>	Loop to previous loop start 'nn' times.
LPS	Loop starting Phase.
LPE	Loop end Phase.
PAS <number data>	Pauses pumping for 'nn' seconds.
PAS n.n	Pauses pumping for 'n.n' seconds.
IF <phase data>	If Program input TTL pin low, jump to Phase.
EVN <phase data>	Set event trigger trap.
EVS <phase data>	Set event square wave trigger trap.
EVR	Event trigger reset.
BEP	Sound short beep.
OUT <TTL level>	Set programmable output pin.

PUMPING RATE

RAT [<float> [<rate units>]]

Set/query pumping rate.

<rate units> =>	UM	= μl/min
	MM	= ml/min
	UH	= μl/hr
	MH	= ml/hr

Applicable only with “Rate Data Functions”.

When setting the pumping rate, if the current Phase’s function is not ‘RATE’, then <rate units> is not applicable.

While pumping, the pumping rate can only be set if the current Phase function is ‘RATE’ and the next Program Phase’s function to be executed is not Increment (FUN INC) or Decrement (FUN DEC). Also, while pumping, <rate units> can not be set.

The new pumping rate will only be stored in non-volatile memory if the Pumping Program is not operating.

When the pumping rate is queried while pumping, the response will be the current pumping rate and units. Otherwise, the response will be the rate setting and units, if applicable. With the Increment and Decrement functions, these two responses are not the same.

VOLUME TO BE DISPENSED

VOL [<float>]

Set/query volume to be dispensed. Applicable only with “Rate Data Functions”. Can only be set when the Pumping Program is not operating. The volume units are set according to the current syringe diameter setting.

Query response:

<float> <volume units>

PUMPING DIRECTION

DIR [INF | WDR | REV]

Set/query pumping direction

INF	= Infuse
WDR	= Withdraw
REV	= Reverse pumping direction

Applicable with all Program Phase functions. Cannot be set when the Pumping Program is operating and the “Volume to be Dispensed” is non-zero.

The pumping direction cannot be changed if an alarm condition exists.

Query response:

{ INF | WDR }

8.5.2 Pump Operational Commands

START PUMPING PROGRAM

RUN [<phase data>]

Starts the Pumping Program operation.

If the Pumping Program was paused, then the Pumping Program resumes at the point where it was stopped. Otherwise, the Pumping Program starts from Phase 1.

If a Phase number is specified (<phase data>), then the Pumping Program will start at the specified Phase number.

The pump cannot be started if an alarm condition exists.

STOP PUMPING PROGRAM

STP

If the Pumping Program is operating, the pump will be stopped and the Pumping Program will be paused.

If the Pumping Program is paused, the stop command will cancel the pause and reset the Pumping Program.

VOLUME DISPENSED

DIS

Queries volume dispense only. Set not applicable.

Response:

I <float> W <float> <volume units>

Where: "I <float>" refers to the infusion volume dispensed, and "W <float>" refers to the withdrawn volume.

CLEAR VOLUME DISPENSED

CLD { INF | WDR }

Sets the Infused or withdrawn volume dispensed to 0. Command is only valid while the Pumping Program is not operating. Query is not applicable.

INF = Infusion volume

WDR = Withdrawn volume

Query is not applicable.

8.5.3 Configuration and Setup Commands

New settings for any of the following commands will be stored in the non-volatile memory.

SET PUMP NETWORK ADDRESS AND BAUD RATE

* ADR [<address> [B { 19200 | 9600 | 2400 | 1200 | 300 }]]
[DUAL | RECP]

Set/query pump network address

<address> => <n> [<n>]

<address> Valid range: 0 to 99

B { 19200 | 9600 | 2400 | 1200 | 300 } will change the baud rate as indicated. NOTE: The command response and all further communications will be at the specified baud rate.

DUAL Sets the pump to Dual Pumping mode with a secondary pump.

RECP Sets the pump to Reciprocating Pumping mode with a secondary pump.

With both Dual and Reciprocating modes, the baud rate defaults to 19,200.

This is a special system command that will be accepted by the pump regardless of its current address. Once set, the pump will only respond to commands with the set address and at the specified baud rate.

Note: Once DUAL or RECP is set, the pump will only respond to commands that are preceded by the ‘*’ character. To exit DUAL or RECP mode, reset the address: * ADR 0

Example: *ADR	Query current address setting
*ADR 3	Set pump network address to 3. The pump will now only respond to commands with address 3
*ADR 5 B 1200	Set the pump network address to 5 and the baud rate to 1200. The command response will be at 1200 baud

ENABLE SAFE COMMUNICATIONS MODE

SAF [<time out>]

Set/query Safe communications mode setting.

<time out> => <n> [<n> [<n>]]

<time out> Valid range: 0 to 255.

if <time out> = 0 then Basic communication mode is set, disabling Safe mode,

If <time out> > 0 then Safe communications mode is enabled. After the reception of this command, valid communications must be received every <time out> seconds.

ALARM SETUP

AL [<on-off>]

Set/query alarm setup mode. Set alarm enables or disables alarm buzzer mode.

POWER FAIL SETUP

PF [<on-off>]

Set/query Power Failure mode. Set Power Failure enables or disables Power Failure mode.

TTL I/O OPERATIONAL TRIGGER SETUP

TRG [<trigger setup>]

Set/Query TTL I/O Operational Trigger input configuration.

TTL I/O Operational Trigger is set to <trigger setup>.

<trigger setup> =>	FT	= Foot switch trigger (falling edge)
	LE	= TTL Level trigger (rising and falling edge)
	ST	= Start only trigger (falling edge)
	SP	= Stop only trigger (falling edge)

TTL I/O DIRECTIONAL CONTROL INPUT SETUP

DIN [0 | 1]

Set/query directional control input setup

Settings => 0 = Falling edge: Infuse, Rising edge Withdraw

Use this setting with the CBL-TTL-1, reciprocating pump cable, to create a 2 pump continuous infusion system

1 = Falling edge: Withdraw, Rising edge Infuse

Use this setting with the CBL-TTL-1, reciprocating pump cable, to create a 2 pump dual pumping system

PUMP MOTOR OPERATING TTL OUTPUT CONFIGURATION

ROM [<on-off>]

Set/query Pump Motor Operating TTL output configuration (TTL pin 7)

Settings => 0 = Output is logic high only when the pump motor is operating (pumping).

1 = Output is logic high when the pump motor is operating (pumping) or when the Pumping Program is executing a pause timer.

SET KEY BEEP

BP [<on-off>]

Set/query key beep mode. Set key beep enables or disables key beep mode.

This command is not relevant to models NE-500/501.

8.5.4 General Control and Status Commands**TTL I/O OUTPUT SETTING**

OUT <n> <TTL level>

Sets TTL level on user definable output pin on the 'TTL I/O' connector.

<n> Indicates pin number on 'TTL I/O' connector

Valid value: 5 (Program Output pin)

Query is not applicable.

TTL INPUT QUERY

IN <n>

Queries TTL level of pin on 'TTL I/O' connector. Set is not applicable.

<n> Indicates pin number on 'TTL I/O' connector

Valid values: 2, 3, 4, and 6.

Response: <TTL level>

BUZZER

BUZ [0 | { 1 [<n>] }]

Sets / queries buzzer

Set: 0 = Turn buzzer off;

1 = Turn buzzer on

if <n> specified

If <n> = 0, buzzer beeps continuously,
otherwise buzzer beeps <n> times

if <n> not specified, buzzer sounds continuously

Query response: { 0 | 1 }

0 = Buzzer off

1 = Buzzer is on continuously or beeping.

FIRMWARE VERSION QUERY

VER

Response: NE50<n>V <n> . <n>

where '<n>.<n>' is current model and firmware version number.

Set is not applicable.

MASTER PROGRAM RESET

* RESET

Clears program memory and resets communication parameters to Basic mode and address 0.

This is a special system command that will be accepted by the pump regardless of its current address.

8.6 Getting Started With RS-232

Before beginning to develop pump control software for a computer, first setup and experiment with the pump's communication. After attaching the pump to the computer, run a terminal emulation Program on the computer. A generic terminal emulator, supplied as standard software with many computers, can be used to communicate with the pump in the Basic communications mode.

New Era Pump Systems Inc. supplies a terminal emulator, for demonstration purposes only, which allows more complex control of the pump. Also, this terminal emulator contains a "Pump Programming Language" (PPL™), which allows Pumping Programs to be developed using symbolic text, modified, and stored in computer files, then downloaded to the pump.

With a generic terminal emulator, setup the terminal emulator with the same baud rate as the pump and with an 8 bit data, no parity, and 1 stop bit (8N1) data frame. Set the communications port to the port that is attached to the pump. Also enable local echo (half-duplex) and turn flow control off.

From the terminal emulator, you can interactively control the pump by typing in commands on your computer and seeing the pump's responses on your screen. This will give you a feel for how the commands work in addition to allowing you to quickly develop the control sequence that will eventually be coded into the software being developed.

The final benefit of using a terminal emulator is the elimination of several variables if the control software does not work properly. If the pump works correctly with the terminal emulator, then this verifies that the hardware is working properly and will work with any software. Any communications problems can then be narrowed down to the control software.

9. Logic Interface: TTL Input and Output

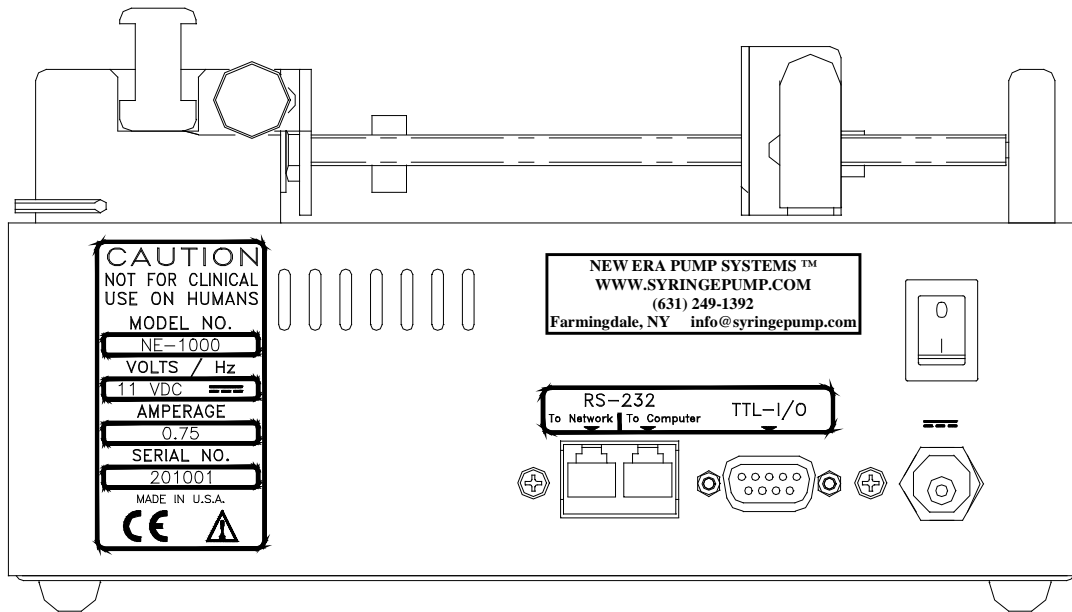

Figure 1: Rear of Pump

On the rear of the pump is a DB-9 connector, labeled 'TTL-I/O', which is used for TTL I/O. The logic signals on this connector permit bi-directional control with external equipment.

Control input TTL logic levels must be held steady for a minimum of 100 ms to be recognized. To minimize the possibility of false signals caused by glitches and ringing, which could be caused by the closure of mechanical switches, TTL control inputs are software filtered. With a sampling period of 50 ms, glitches of less than 100 ms are filtered out.

Edge detection requires the detection of a change in TTL levels. With a minimum of 100 ms to detect a level, an edge requires a minimum of 200 ms to be detected. Since the next level change can be detected in 100 ms, creating another edge, the maximum edge to edge frequency is 10 Hz.

Edge changes to the 'Pumping Direction' and 'Operational Trigger' inputs must occur at least 50 ms apart.

Falling edge refers to a logic high to logic low transition. Rising edge refers to a logic low to a logic high transition. To guarantee recognition of logic levels, voltages on the input lines must be within the following ranges:

TTL logic low (0):	0 to 0.9 V
logic high (1):	3.5 to 5.25 V

The Vcc and Ground pins, pins 1 and 9, are for logic reference only. To assure proper voltage levels, the Ground pin should always be connected to the signal ground of a sensing or controlling device that is attached to any other pin on the TTL I/O connector. The Vcc pin should not be used to source current. The TTL I/O pins are defined as follows:

Pin #	Definition	Type	Function
1	Vcc (5V)	Reference	Logic high reference. Power on indicator.

2	Operational Trigger	Input	Configurable start/stop operational trigger input. Foot Switch Level Start only Stop only	Falling edge: Start or stop trigger Falling edge: Stop trigger Rising edge: Start trigger Falling edge: Start trigger Falling edge: Stop trigger
3	Pumping Direction	Input	Changes pumping direction according to setup Command: DIN 0 Falling edge: Infuse Rising edge: Withdraw	DIN 1 Withdraw Infuse
4	Event Trigger	Input	Event input or user definable input	
5	Program Output	Output	Program controlled output or user definable output	
6	Program Input	Input	Program conditional input read by the "IF" program function. Also user definable input. Also used by the keypad lockout function.	
7	Pump Motor Operating	Output	[RUN.0] High: Pumping; Low: Not pumping [RUN.1] High: Pumping or Pause timer Low: Not pumping	
8	Pumping Direction	Output	High: Infuse; Low: Withdraw	
9	Ground (0V)	Reference	Logic low reference	

9.1 TTL I/O Operational Controls

While the user is changing settings or configuration from the keypad, external control by the 'Pumping Direction' and 'Operational Trigger' inputs will be ignored. These controls will also be ignored if an alarm condition exists.

Operational Trigger (Pin 2): The input signal on this pin controls the operation of the Pumping Program. Its functionality is user configurable. Use the 'TRG' command to configure this input pin (See Section 06.4, TTL I/O Operational Trigger Configuration).

Each option, Foot Switch, Level Control, and Start Only, define when the Operational Trigger input is activated. When activated, the trigger emulates a 'Start/Stop' key.

Foot Switch: Operates like a 'Start/Stop' key, whereby each falling edge (contact to ground) either starts or stops/pauses the Pumping Program.

Level Control: Falling edge stops/pauses the Pumping Program, Rising edge starts the Pumping Program. This configuration can be used with a contact closure timer or in an automation setup, allowing logic level control over the operation of the pump.

Start Only: Falling edge starts the Pumping Program. This configuration only allows the starting of the Pumping Program. This would be useful, for example, with a laboratory animal trained to press a lever. The animal can start the Pumping Program, but repeated presses would have no affect until the Pumping Program permits it.

Stop Only: Falling edge Stops the Pumping Program. This configuration only allows the stopping/pausing of the Pumping Program. This would be useful, for example, with an end of travel limit switch. Also, this switch can be used as a power on homing switch.

Pump Motor Operating (Pin 7): This output provides an external signal indicating when the pump motor is operating. This pin is configured with the ROM <n> setup command. When set to 0, the output is only at logic high when the motor is operating (pumping). When set to 1, the output is logic high when the motor is operating or when the Pumping program is executing a pause timer. Otherwise, the output is a

logic low.

Pumping Direction Controls (Input: Pin 3; Output: Pin 8): Allows bi-directional control of the pumping direction. The input pin, when activated, can be used to change the pumping direction. This function, therefore, is only applicable when the pumping direction change is applicable. The function of the input pin is configured with the "DIN <n>" command.

When the mode is set to reciprocating pumps (DIN 0), then if the current pumping direction is withdraw, a falling edge sets the direction to infuse. If the current pumping direction is infuse, a rising edge sets the direction to withdraw. Otherwise, this input pin has no affect.

When the mode is set to dual pumps (DIN 1), then if the current pumping direction is withdraw, a rising edge sets the direction to infuse. If the current pumping direction is infuse, a falling edge sets the direction to withdraw. Otherwise, this input pin has no affect.

Dual and reciprocating pumping systems are created using 2 pumps attached with the accessory cable CBL-TTL-1.

The output pin provides an output signal to external devices indicating the direction of pumping. A logic low indicates withdraw, and a logic high indicates infuse. For example, this pin can be used to control an external valve, allowing the syringe to refill from a reservoir.

9.2 TTL I/O Control from the Pumping Program

Various Pumping Program functions can define how the pump reacts to levels on the TTL I/O connector or set output levels. These are summarized in the following table:

Pumping Program Function	TTL I/O Control Pin	Pin #	Action
FUN OUT <n>	Program Output	5	Set logic level output to 'n'
FUN EVN <nn>	Event Trigger	4	Low level when executed or a falling edge afterward, until canceled, causes a jump to Phase 'nn'
FUN EVS <nn>	Event Square wave Trigger	4	Rising or falling edge triggers a jump to Phase 'nn'
FUN IF <nn>	Program Input	6	Low level causes a jump to Phase 'nn'
FUN PAS 00	Operational Trigger	2	Trigger activation resumes Program operation

9.3 TTL I/O Control From RS-232

The logic levels of pins 2, 3, 4, and 6 can be queried from an attached computer using the RS-232 'IN' command.

The output logic level of pin 5 can be set with the RS-232 'OUT' command.

10. Appendix

10.1 Syringe Diameters and Rate Limits

Manufacturer	Syringe Size (cc)	Inside Diameter (mm)	Maximum Rate (ml/hr)	Minimum Rate (µl/hr)
B-D	1	4.699	53.07	0.73
	3	8.585	177.1	2.434
	5	11.99	345.5	4.748
	10	14.43	500.4	6.876
	20	19.05	872.2	11.99
	30	21.59	1120	15.4
	60	26.59	1699	23.35
Monoject	1	5.74	79.18	1.088
	3	8.941	192.1	2.64
	6	12.7	387.6	5.326
	12	15.72	593.9	8.161
	20	20.12	972.9	13.37
	35	23.52	1329	18.27
	60	26.64	1705	23.44
Terumo	1	4.7	53.09	0.73
	3	8.95	192.5	2.646
	5	13	406.1	5.581
	10	15.8	600	8.244
	20	20.15	975.8	13.41
	30	23.1	1282	17.63
	60	29.7	2120	29.13
Air-Tite	10	15.9	607.6	8.349
	20	20.25	985.5	13.55
	30	22.5	1216	16.72
	50	29	2021	27.78
	Syringe Size (uL)	Inside Diameter (mm)	Maximum Rate (ul/hr)	Minimum Rate (µl/hr)
Hamilton Microliter	0.5	0.103	25.49	0.001
	1	0.146	51.23	0.001
	2	0.206	101.9	0.002
	5	0.326	255.4	0.004
SGE	0.5	0.1	24.03	0.001
	1	0.15	54.07	0.001

10.2 RS-232 Command Summary

<command> =>	
DIA [<float >]	Syringe inside diameter
PHN [< phase data >]	Program Phase number
FUN [< phase function >]	Program Phase function
< phase function > =>	
RAT	Pumping rate. 'RATE'
INC	Increment rate. 'INCR'
DEC	Decrement rate. 'DECR'
STP	Stop pump. 'STOP'
JMP <phase data>	Jump to Program Phase. 'JP:nn'
PRI	Program Selection Input. 'Pr:In'
PRL <count data>	Program Selection Label definition. 'Pr:nn'
LOP <count data>	Loop to previous loop start 'nn' times. 'LP:nn'
LPS	Loop starting Phase. 'LP:ST'
LPE	Loop end Phase. 'LP:EN'
PAS <number data>	Pauses pumping for 'nn' seconds. 'PS:nn'
PAS [n.n]	Pauses pumping for 'n.n' seconds. 'PS:n.n'
IF <phase data>	If Program input low, jump to Program Phase. 'IF:nn'
EVN <phase data>	Set event trigger. 'EV:nn'
EVS <phase data>	Set event square wave trigger. 'ES:nn'
EVR	Event trigger reset. 'EV:RS'
BEP	Sound short beep. 'BEEP'
OUT { 0 1 }	Set programmable output pin. 'OUT.n'
RAT [<float> [UM MM UH MH]]	Pumping rate
VOL [<float>]	Volume to be Dispensed
DIR [INF WDR REV]	Pumping direction
RUN [<phase data>]	Starts the Pumping Program
STP	Stop/pauses the Pumping Program
DIS	Query volume dispensed
CLD { INF WDR }	Clear volume dispensed
SAF [<n> [<n> [<n>]]]	Safe communications mode
AL [<on-off>]	Alarm mode
PF [<on-off>]	Power failure mode
TRG [FT LE ST]	Operational trigger mode
DIN [0 1]	Directional input control mode
ROM [0 1]	Pump Motor Operating TTL output mode
OUT 5 { 0 1 }	Set TTL output level
IN { 2 3 4 6 }	Query TTL input level
BUZ [0 { 1 [<n>] }]	Buzzer control
VER	Query firmware version
*ADR [<n> [<n>] [B <baud-rate>]]	Network address and baud rate (system command, valid regardless of current address)
*ADR [DUAL RECP]	Set Reciprocating or Dual pumping mode
*RESET	Clears program memory and resets communication parameters (system command, valid regardless of current address)

10.3 RS-232 Pump Network Connector Wiring

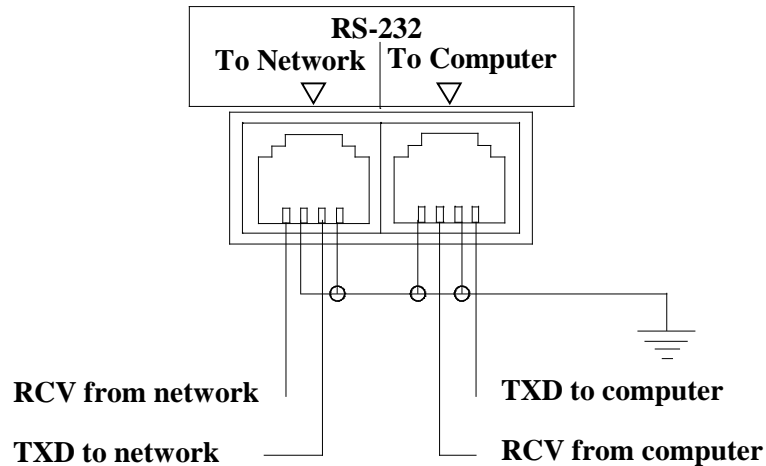

PC Com Port Connectors

25 Pin

3 - Receive
2 - Transmit
9 - Ground

9 Pin

2 - Receive
3 - Transmit
5 - Ground

Connect to pump TXD
Connect to pump RCV
Connect to pump GND

10.4 Accessories

10.4.1 ANA-BOX

Part #: ADPT-ANABOX, Analog sensor interface.

Creates a closed loop system allowing the NE-1000 to be controlled by an external sensor, such as a pressure sensor, or other variable voltage source. Start or stop the pump at a specific voltage level. Set the pumping rate to be proportional to the voltage input.

10.4.2 Syringe Heater

Part#: SYRINGE-HEATER

Flexible heater that wraps around the syringe. Digital PID controller will heat syringe to over 100 C.

10.4.3 RS-232 Network Cables

RS-232 Network Primary Cable

7 foot cable, part #: CBL-PC-PUMP-7
25 foot cable, part #: CBL-PC-PUMP-25

Cable to connect a pump, or the first pump in a pump network, to a standard personal computer's serial port with a DB-9 or DB-25 connector. Included with this cable is a 9 pin to 25 pin converter.

RS-232 Network Secondary Cable

7 foot cable, part #: CBL-NET-7
25 foot cable, part #: CBL-NET-25

Cable to connect additional pumps, after the first pump, to the pump network.

10.4.4 Automation Cable: Reciprocating/Dual Pumps Control Cable

Part #: CBL-DUAL

Using two NE-1000 family syringe pumps, this cable either creates an automated, continuous operation pumping system, whereby one pump is refilling while the other is dispensing, or creates a dual pumping system, with both pumps operating in the same direction.

This cable is attached to two NE-1000 family syringe pumps via their RS-232 connectors. In this setup, with the pumps configured for this operation, one pump acts as the Master controller. With the Master pump programmed with a continuous infusion program, the other pump will always be pumping in the opposite direction. With proper plumbing, this will create a continuous infusion system.

Alternatively, the pumps can be set to Dual Pump Mode, whereby the second pump will always follow the program on the first pump, including starting, stopping, direction changes, and rate changes.

When either pump stops, for any reason, the other pump stops.

10.4.5 Valve Controller

Part# ADPT-VALVE-INTERFACE-1 (For one pump)

Part# ADPT-VALVE-INTERFACE-2 (For two pumps, includes CBL-TTL-1)

Provides a control interface for your electronic valves. Attach your electronic valves, and the interface will control the activation of the valves. The 2 pump interface is used to create a continuous infusion/refill system.

10.4.6 Foot Switch

Part #: ADPT-2

Allows the pump to be operated from a foot switch. Attaches to the TTL I/O connector.

10.4.7 Firmware Upgrade

Part#: CPU-NE1000X, Gradient/Linear ramping for smooth gradients, plus other new features.

Contact your dealer for this upgrade and to determine the current available version of the pumps internal firmware.

10.5 Troubleshooting and Maintenance

Maintenance: Periodically, a small amount of all-purpose oil should be applied to the guide rods.

The mechanism should be kept clean to prevent impeded operation.

No other special maintenance or calibrations are needed

RS-232 Communications: If no RS-232 communications is possible or garbled responses are received from the pump, check the following:

Verify the correct communications port and that the cable is attached to the "Computer" connection on the pump.

If the Basic communications mode is used, check if the pump is in Safe communications mode. See section 8.3, RS-232 Protocol, for instructions on how to change the communications mode.

Verify the pump's network address.

Pusher block makes a snap or click sound when the pump is started: This is a normal condition.

When the pusher block is manually moved, the drive-nut may not have been fully engaged on the drive screw. The sound heard is the drive-nut engaging on the drive screw.

Pump doesn't stop after dispensing a set volume: The pump was previously setup with a multiple Phase Pumping Program. To simply dispense a fixed volume at a fixed pumping rate, the second Program Phase must be the 'Stop' function. See section 7.1, How to Enter Pumping Programs, for instructions on changing the Pumping Program.

Pump stops pumping after a period of time: A dispense volume has been set. Verify that the dispense volume is set to 0.

10.6 Specifications

10.6.1 Mechanical & Electrical

Syringe sizes:	Up to 60 cc
Number of syringes:	1
Motor type:	Step motor
Motor steps per revolution:	400
Microstepping:	1/8 to 1/2 depending on motor speed
Advance per step:	0.2126 uM to 0.8504 uM depending on motor speed
Motor to drive screw ratio:	15/28
Drive screw pitch:	20 revolutions/”
DC connector:	2.1 mm, center positive
Voltage at DC connector:	12 VDC at full load
Amperage:	750 mA at full load
Power supply type:	Unregulated linear external wall adapter, country and power source specific
Dimensions:	9 1/2” x 4 1/4” x 4 1/8” High (24.13 cm x 10.8 cm x 10.5 cm)
Weight:	2.2 lbs. (1.0 kg)

10.6.2 Operational

Maximum speed:	5.1005 cm/min
Minimum speed:	0.004205 cm/hr
Maximum pumping rate:	1699 ml/hr with a B-D 60 cc syringe
Minimum pumping rate:	0.73 µl/hr with a B-D 1 cc syringe
Maximum force:	35 lbs. at minimum speed, 18 lbs. at maximum speed
Number of Program Phases:	41
RS-232 pump network:	100 pumps maximum
RS-232 selectable baud rates:	300, 1200, 2400, 9600, 19200
Syringe inside diameter range:	0.100 to 50.00 mm

10.7 Custom Applications

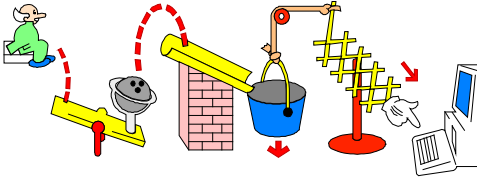

For specialized and OEM applications, contact your dealer or New Era Pump Systems Inc. Custom modifications can be made to the mechanics or the firmware.